

3RD EDITION MAR 2024

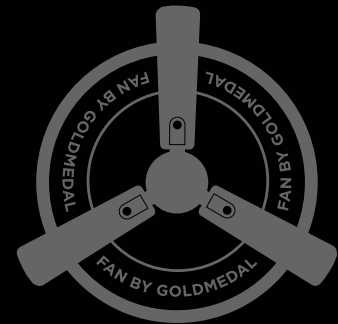

CUSTOMER CARE NO.
9711 09 09 09

Chat with us on WhatsApp for any query or complaint

FAN CATALOGUE MAR/2K24

20
24
FAN CATALOGUE

Goldmedal[®]
SWITCH TO THE AMAZING

DISCOVER THE PERFECT
Breeze
FAN BY GOLDMEDAL







TURN ON THE
Breeze

INTRODUCING, TRUE MASTERPIECES. THE STORY OF PERFECTION IN MOTION.

Considering India's hot and humid climate for the majority of the year, fans are a necessity in most Indian homes. With summer temperatures soaring with every passing year, there's now more reasons to have a fan in every room. Whether it's ceiling fans, wall fans, pedestal fans or ventilator fans, without one of these cooling appliances, you will find it difficult to stay cool and refreshed nowadays. But there's more to bringing home a fan than you thought.

Cooling technology and design has evolved so rapidly that you now have a plethora of choices when selecting a fan. From the right type to the right designs to energy efficiency, noiseless operations, lighting options, smart features, and many more — you can choose fans that meet your exact requirements. As a pioneer in manufacturing high quality wiring devices for more than four decades, Goldmedal incorporates the best in fan manufacturing technology to bring you fans that match your needs, perfectly.

Like our other appliances, Goldmedal fans are also designed and manufactured in India, keeping local climate conditions and needs in mind. We offer fans in every possible combination. Each fan is manufactured to the highest precision so that you experience superior cooling in the most energy-efficient way possible. Goldmedal fans are also designed to add aesthetic value to your room. Whether it's classical, contemporary, decorative, or smart — our fans will not only make your rooms feel cool but also look cool.

Conserve energy, *preserve the planet!*

Fans are one of the most heavily used electrical devices in India. No wonder they are responsible for a substantial part of a typical household's power consumption. At Goldmedal, we aim to help reduce your power bills and contribute to a greener planet through our BLDC fans and star-rated fans. These fans are a marvel of innovation — cutting down power consumption by up to 60%. and also ensure much less power usage compared to traditional fans.

Along with equipping our fans with power-saving capabilities, we also ensure that Goldmedal fans offer high-speed cooling, noiseless operation, and high aesthetic value. Created to meet the needs of contemporary living, Goldmedal fans are designed with advanced aerodynamic features, smart controls, and unique styling that complements the décor of every house. Minimizing energy consumption is the need of the hour and the Goldmedal range of BLDC and star-rated fans promotes an eco-friendly environment for the betterment of all life on earth.

DID YOU KNOW THAT USING GOLDMEDAL STAR RATED FAN FOR 10 YEARS CAN...

Reduce Electricity Consumption By 2686 Kwh
1 kg of coal creates 7.21 Kwh of electricity

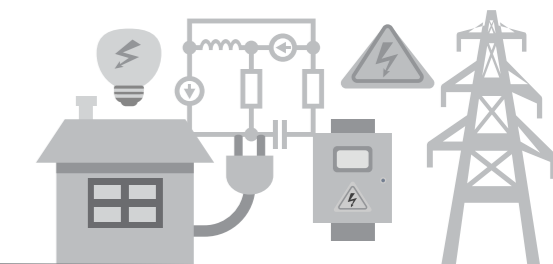

Reduce coal consumption by 372 Kgs
1 kg of coal creates 7.21 Kwh of electricity

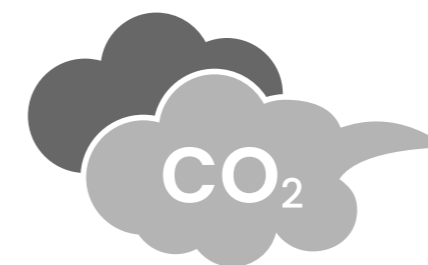

Stop 901 Kg of CO₂ emissions
Burning a single kg of coal contributes to 2.42 Kg of CO₂

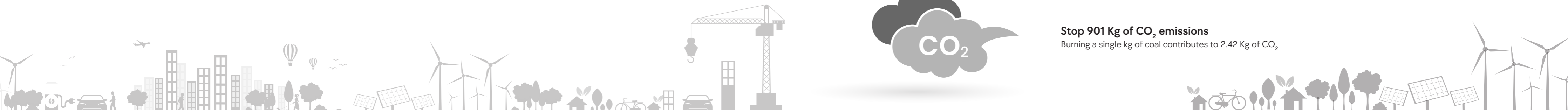

CONTENTS

01

CEILING FANS

12-35

SUPER DECORATIVE

Fabia, Hush Flo BLDC, Hush-Air, Opus Prime BLDC, Daisy, Phantom, Gladiator, Thor

36-51

DECORATIVE

Flora, Hero Prime, Insignia, Hoopla, Senora, Eva Prime, Enzo

52-57

CLASSIC DECORATIVE

Air Crest, Vector, Gati Deco

58-87

STANDARD / ECONOMY

Geo Fox BLDC, Marut BLDC, EN Saver BLDC, Legacy 390, Airavat, Vellfire, Storm, Vegah 400, Volt 650, Volt 400, Gati 400 Neo, Air GT, G-Bliss

02

LIFESTYLE FANS

88-109

LIFESTYLE

Oxyrich, Vista 360, Speedo-X, Grace, Fusion, Tricool, Air Fiesta, Fusion DG (Wall), Fusion (Wall), Adora (Wall)

110-117

PERSONAL / CABIN

I-Fresh, Tristar, Astor, Air On

03

TABLE AND WALL FANS

118-129

TABLE

Storm HS, Storm, Nora, Erica

130-143

WALL

Storm HS, Storm, Nora, Erica, Dyno Pro, Dyno, G-Express

04

PEDESTAL FANS

144-163

PEDESTAL

Storm HS, Storm, Nora, Erica, Dyno Pro, Dyno, Falcon, Falcon Pro, G-Express, Turbo Maxx, Turbo Star

05

AXIAL AND VENTILATION FANS

164-179

AXIAL

Frost, Frost Prime, Air Vent, Nova, Nova Pro, Aero, Aria, Trigo, Vento, Ventflo

180-185

VENTILATION

Air-Maxx, Air-Maxx HS, Air-Maxx Plus, Havoc, Havoc Plus, Rapido



Technological *revolution*



TECHNOLOGY FOR A CHANGING WORLD

For more than forty years, Goldmedal has been introducing some of the best ideas in electrical wiring devices. From mini modular systems to modular systems to home automation systems, LEDs, wires and cables, and more, Goldmedal products have become synonymous with high quality, innovative products.

Along with pioneering many innovations within the industry, Goldmedal has also grown into a leadership position with its pan-India reach and sheer volume of sales. As a brand, Goldmedal is now foraying into newer categories, starting with its exciting range of cooling ideas that include ceiling, wall, pedestal, table, and exhaust fans.

As an appliance that contributes significantly to a household's electricity consumption, fans can be an expensive necessity. Goldmedal is at the forefront of using the latest technologies to ensure that fans leave as low carbon footprint as possible. All Goldmedal induction motor fans are star rated which helps reduce overall power consumption while its BLDC fans can bring down power consumption by as much as 60%.

Goldmedal's portfolio includes BLDC as well as star-rated power-saving fans in standard, decorative, and smart categories that satisfy a wide variety of needs and aesthetic preferences. Attention is paid to the minutest detail to ensure that every fan delivers in terms of function and style. The company's extensive, nation-wide presence ensures seamless delivery and service while its network of branches in every state ensures ready support to all its channel partners.

Designed for modern lifestyles, the new Goldmedal range of fans are masterpieces in the truest sense. Designed, developed, and manufactured entirely in India, the fans by Goldmedal are a continuation of the company's Made in India endeavour.

A SYMPHONY OF ELEGANCE & PERFORMANCE

A perfect blend of art and utility, the Super Decorative Ceiling Fans from Goldmedal are more than just devices for air circulation. Each fan can be a masterpiece of design, crafted to leave a lasting impression. Adorned with exquisite patterns and artistic flourishes, these fans offer a spectrum of designs — from bold, modern geometrical lines to delicate swirls of traditional motifs, and more, all tailored to elevate contemporary interiors with finesse. Crafted from premium materials like wood, composite, or metal, and available in finishes ranging from lustrous metallic to understated matte, they seamlessly complement any decor.

Beyond their stunning appearances, the fans boast a powerful motor for efficient air circulation that ensures comfort in every season. Select models enhance the experience with energy-saving LEDs, a user-friendly remote control, and near-silent operations. These fans represent a symphony of elegance and functionality, making them ideal for modern homes.



Super
decorative
ceiling fans



FABIA

Super Decorative Ceiling Fan



Vanilla Metallic White



Himalayan Grey

FABIA

Super Decorative Ceiling Fan



WITH EXTRA
COPPER

SUPERIOR
PAINT FINISH

ANTI DUST

Elevate your space with the Fabia ceiling fan, available in Vanilla Metallic White and Himalayan Grey. Engineered for performance, it boasts of high-grade copper windings and double ball bearings for exceptional airflow and durability. Enjoy a customizable ambiance with its 3-colour LEDs and remote control. Perfect for modern living, the Fabia is the ultimate combination of elegance and performance in one.

PRODUCT HIGHLIGHTS

- 3 Colour LED With Remote · Elegant Design · Amazingly Efficient · Exceptional Air Flow
- 2 Years Warranty · Off Timer Function (2,4 & 8 Hrs)



ITEM CODE	SWEEP	WATTAGE	SPEED	AIR DELIVERY
SCFZ 101948	1200 mm	53 W	350 RPM	220 CMM



HUSH FLO BLDC
Super Decorative Ceiling Fan





Satin White

Dayton Grey

American Walnut

PRODUCT HIGHLIGHTS

- 6 LED Lights To Indicate Speed Levels With Remote Control
- Off Timer Function (2,4, & 8 Hrs)
- ABS Decorative Blades
- Innovative & Contemporary Design
- Optimum Air Flow Even At Low Voltage
- No Humming Sound While Running On Inverter
- 2 Years Warranty



HUSH FLO BLDC
Super Decorative Ceiling Fan

Redefine your living experience with the Hush Flo BLDC fan. Its six-LED light setup, controlled remotely, offers soft ambient lighting. Enjoy quiet operation and contemporary design that complements modern interiors. It ensures superior air delivery with a high-performance motor and sleek ABS decorative blades. Tailor your comfort with a 2, 4, and 8-hour off timer function.

ITEM CODE	SWEEP	WATTAGE	SPEED	AIR DELIVERY
SCFZ 101050	1250 mm	36 W	300 RPM	230 CMM





Coffee Brown



Satin White



American Walnut



Dayton Grey

PRODUCT HIGHLIGHTS

- Smooth & Silent Operation · Innovative & Contemporary Design · Amazingly Stylish
- High Air Delivery · ABS Decorative Blades · 2 Years Warranty



HUSH-AIR

Super Decorative Ceiling Fan

Enjoy the pleasure of a cool breeze in the midst of summer with the Hush-Air BLDC super decorative ceiling fans. With a powerful motor and an innovative blade design, the Hush-Air offers high-speed performance, noiselessly. This incredibly efficient and amazingly stylish fan will offer excellent airflow to every corner of your room!

ITEM CODE	SWEEP	WATTAGE	SPEED	AIR DELIVERY
CFZ 100750	1250 mm	53 W	300 RPM	230 CMM



OPUS PRIMĒ BLDC
Super Decorative Ceiling Fan

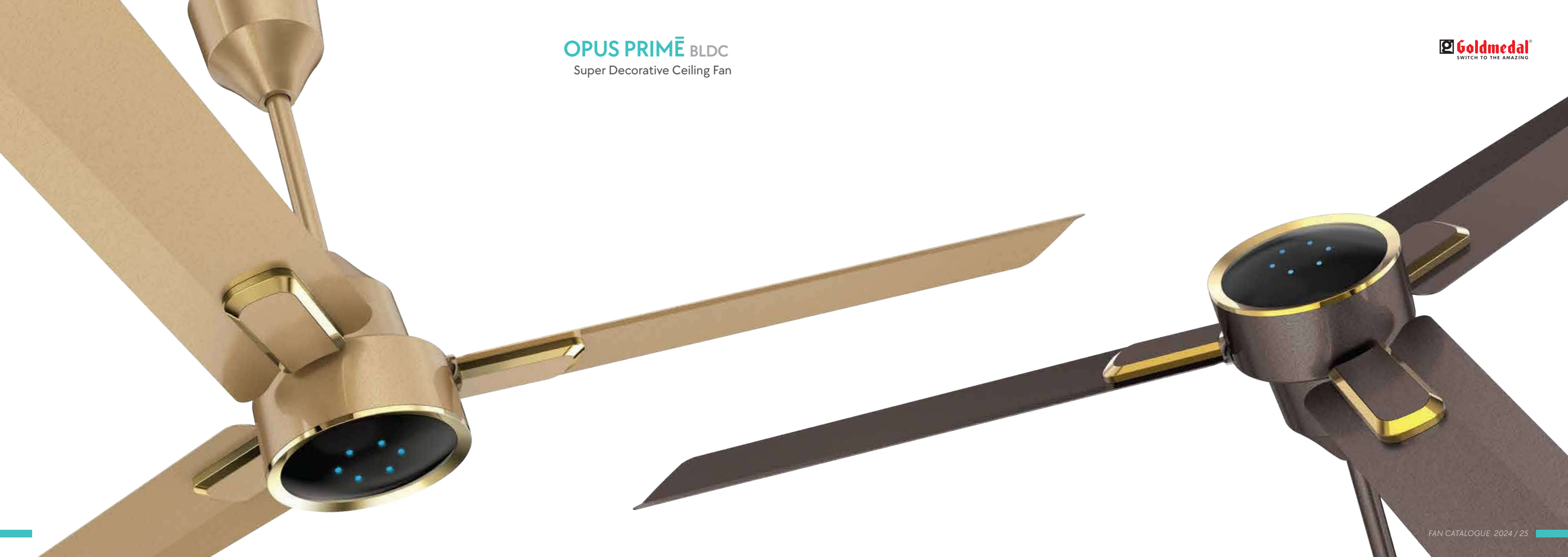



OPUS PRIMĒ BLDC
Super Decorative Ceiling Fan



Embrace innovation with the Opus Prime BLDC Fan, combining style and energy-saving performance. Its efficient 28-watt BLDC copper motor outperforms traditional fans by 60%. Features like silent operation, remote-controlled LED lights, and an elegant, durable design ensure optimal airflow and convenience, all in a sleek, anti-dust package.



Angel White



Golden Dune



Pearl Brown



Titanium Grey

PRODUCT HIGHLIGHTS

- 6 LED Lights To Indicate Speed Levels With Remote Control
- Off Timer Function (2, 4, & 8 Hrs)
- Elegant Motor Design
- 60% More Efficient Than Conventional Fans
- Optimum Air Flow Even At Low Voltage
- No Humming Sound While Running On Inverter



ITEM CODE	SWEEP	WATTAGE	SPEED	AIR DELIVERY
SCFP 301948	1200 mm	30 W	350 RPM	225 CMM

*Extended warranty subject to registration





Antique Brass Dark Wood



Antique Copper Rose Wood

PRODUCT HIGHLIGHTS

- Magnificent Carvings For A Royal Decor · 100% High Quality Copper Motor · Elegant Design
- LED Light Source · Decorative Lampshades To Enhance Beauty · Electroplated Finish
- Exceptional Airflow · Innovative Design · Incredibly Quiet · 2 Years Warranty



DAISY

Super Decorative Ceiling Fan

Elegantly carved Daisy ceiling fans are a perfect combination of form and function! The fan looks imperial with striking features and decorative lampshades. It is equipped with a super quiet copper motor and electroplated blades that guarantees brilliant airflow. Available in two elegant electroplated wooden finishes, the fan can also be operated with a remote. The Daisy fan is a luxury that you can't miss adding to your living room.

ITEM CODE	SWEEP	WATTAGE	SPEED	AIR DELIVERY
SCFZ 101448	1200 mm	40 W	330 RPM	210 CMM





Antique Brass Dark Wood



Antique Copper Rose Wood



Antique Silver Dark Wood

PHANTOM

Super Decorative Ceiling Fan

The Phantom super decorative fan is a delightful mix of classical and modern styles and adds an extra dimension to your decor. It offers exciting features like six blades and an under-light that can glow in three colours and different brightness levels. The Phantom is available in three antique finishes and can be operated with a remote.



PRODUCT HIGHLIGHTS

- Incredibly Quiet · 3 Colour LED With Remote · Amazingly Efficient · Exceptional Air Flow
- Elegant Design To Complement Room Decor · 2 Years Warranty



ITEM CODE	SWEEP	WATTAGE	SPEED	AIR DELIVERY
SCFZ100148	1200 mm	40 W	330 RPM	210 CMM





GLADIATOR

Super Decorative Ceiling Fan

ELECTROPLATED FINISH  **WOOD FINISH BLADES** 

Beat the heat in style with the incredibly quiet Gladiator super decorative ceiling fans. This electroplated decorative fan with unique antique metal finishes functions as good as it looks. Fitted with a powerful motor that is enhanced with extra high grade copper, the Gladiator is your warrior to fight against the heat!

PRODUCT HIGHLIGHTS

- Smooth & Silent Operation · Electroplated Finish · Amazingly Efficient · Superior Air Delivery
- High Grade Copper · 2 Years Warranty



ITEM CODE	SWEEP	WATTAGE	SPEED	AIR DELIVERY
SCFZ 100948	1200 mm	52 W	350 RPM	220 CMM





Antique Brass
Wenge Wood



Antique Copper
Rose Wood



Antique Steel
Wenge Wood

THOR

Super Decorative Ceiling Fan

WITH EXTRA
COPPER

WOOD FINISH
BLADES

The Thor ceiling fan is an example of how some of the best things in life come in small packages. A unique, four-blade fan, the Thor has an electroplated body and is available in a variety of wood finishes. Bold, fresh, stylish yet compact and minimal, the Thor has a beast of a motor that is supremely quiet yet cools the space around it in an extremely short time.

PRODUCT HIGHLIGHTS

- Electroplated Decorative · Amazingly Efficient · Exceptional Air Flow
- High Grade Copper · 2 Years Warranty



ITEM CODE	SWEEP	WATTAGE	SPEED	AIR DELIVERY
CFZ 101124	600 mm	65 W	850 RPM	105 CMM





Decorative *ceiling fans*

IMPERIAL IMPRESSIONS

Step into a world where elegance swirls above you, and innovation breathes new life into your space. Designed to complement a wide range of interior styles, the decorative ceiling fans seamlessly blend into any décor, adding a subtle, stylish charm.

But these fans are not just about aesthetics. They are engineered for optimal comfort with features like multiple speed settings and a reversible motor, ensuring efficient performance in all seasons. The decorative ceiling fans embody elegance and efficiency, making them a perfect addition to any home looking to elevate its style.



**ELECTR
PLATED
FINISH**

**WOOD FINISH
BLADES**

FLORA
Decorative Ceiling Fan

The Flora is inspired by the naturally occurring shape of flower petals. Apart from the aesthetic appeal of these fans, their aerodynamic blade design ensures superior airflow even at low speeds which makes them more energy efficient than conventional fans. These fans also create lower air turbulence and wind noise and are the ideal option for modern interiors.



Antique Copper
Rose Wood



Antique Brass
Wenge Wood



Antique Copper
Choco Brown

PRODUCT HIGHLIGHTS

- Incredibly Quiet · Exotic Rich Looks · Extremely Efficient · Superior Air Delivery
- Electroplated Ring & Trims · 2 Years Warranty



ITEM CODE	SWEEP	WATTAGE	SPEED	AIR DELIVERY
SCFP 300348	1200 mm	52W	350 RPM	220 CMM





Metallic Grey



Imperial Gold



Metallic Luster Brown



Angel White

PRODUCT HIGHLIGHTS

- Incredibly Quiet · Wider Blade For Better Air Thrust · Amazingly Efficient
- Elegant Design With Stylish Trims · Superior Metallic Paint Finish



HERO PRIME
Decorative Ceiling Fan

The Hero Prime is a stylish yet practical fan that can perform silently in all conditions. Its aluminum blades and compact body are coated with superior, anti-corrosive metallic finish paint that enables the fan to maintain its high-gloss look for years. With a powerful motor, the Hero Prime ensures a lifetime of trouble-free use.

ITEM CODE	SWEEP	WATTAGE	SPEED	AIR DELIVERY
SCFP 301548	1200 mm	53 W	380 RPM	230 CMM



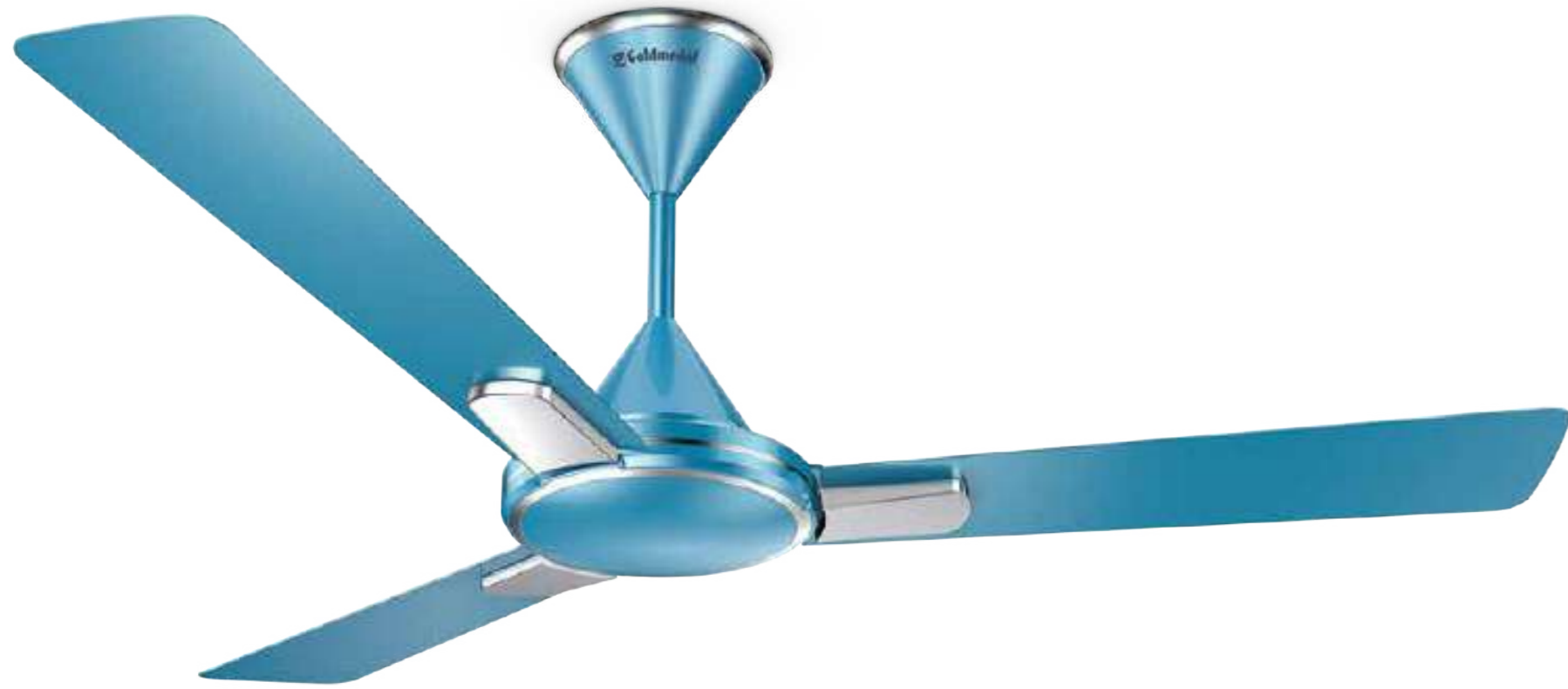

Espresso Brown



Topaz Gold



Indigo Blue



Carbon Black



Angel White

INSIGNIA

Decorative Ceiling Fan



The Insignia decorative fan is a stylish solution to beat the scorching heat of the summer months. Meticulously designed with premium fittings, the Insignia is an aerodynamically superior fan that offers excellent air flow while being extremely quiet and efficient. Available in five exciting shades, the Insignia makes you look and feel cooler!

PRODUCT HIGHLIGHTS

- Incredibly Quiet · Bold Design For Modern Homes · Extremely Efficient · Exceptional Air Flow
- Superior Metallic Paint Finish · High Grade Copper · 2 Years Warranty



ITEM CODE	SWEEP	WATTAGE	SPEED	AIR DELIVERY
SCFP 300536	900 mm	41 W	400 RPM	130 CMM
SCFP 300548	1200 mm	53 W	380 RPM	220 CMM
SCFP 300556	1400 mm	59 W	310 RPM	245 CMM





Titanium Silver



Cobalt Blue



Champagne Gold



Tawny Brown

PRODUCT HIGHLIGHTS

- Incredibly Quiet · Elegant Design · Amazingly Efficient · Exceptional Air Flow
- High Grade Copper · Superior Metallic Paint Finish · 2 Years Warranty



HOOPLA
Decorative Ceiling Fan

The shimmering and sophisticated Hoopla decorative ceiling fan is as good as it looks. In the classic combination of delicate metallic rings on the motor with a premium embellishment on the blades, the Hoopla is designed to suit contemporary tastes and modern homes. With its high energy efficiency and powerful performance, the Hoopla will liven up your room as well as your spirits!

ITEM CODE	SWEEP	WATTAGE	SPEED	AIR DELIVERY
SCFP 301136	900 mm	45 W	450 RPM	140 CMM
SCFP 301148	1200 mm	53 W	380 RPM	225 CMM





SENORA
Decorative Ceiling Fan



There are fans that stand out, and then there is the Senora that spells class from every angle. Designed for modern, contemporary lifestyles, the Senora can be a star fitting in most Indian homes. Its fluid-shaped trimmings contrast eloquently with its body colour, making it a truly mesmerizing sight. Adding to its allure is its anti-dust feature that makes the Senora maintain its superior finish for a really long time. For all its beauty, the Senora is a truly efficient fan, delivering effective cooling on demand.



Chocolate Gold



Midas Gold



Cobalt Silver



Grey Goose



Rose Gold

PRODUCT HIGHLIGHTS

- Incredibly Quiet · Dual Tone Finish · Amazingly Efficient · Exceptional Air Flow
- High Grade Copper · 2 Years Warranty



ITEM CODE	SWEEP	WATTAGE	SPEED	AIR DELIVERY
SCFP 300948	1200 mm	52 W	380 RPM	220 CMM





Royal Blue



Royal Lavender



Metallic Grey



Rose Gold



Metallic White

PRODUCT HIGHLIGHTS

- Incredibly Quiet · Rich Trendy Looks · Extremely Efficient · Exceptional Air Flow
- Superior Metallic Paint Finish · High Grade Copper · 2 Years Warranty



EVA PRIME
Decorative Ceiling Fan

When you need a fan that doesn't just deliver superior performance but also optimises the interiors of your home or office, look no further than the EVA Prime. Exquisitely finished in high-quality paint, the EVA Prime stands out from the rest due to its rich, exclusive shades. The trimmings on this fan are minimal, yet noticeable in a contemporary manner. Its noiseless operation is another feature that makes the EVA Prime simply an outstanding piece of engineering.

ITEM CODE	SWEEP	WATTAGE	SPEED	AIR DELIVERY
SCFP 301748	1200 mm	52 W	350 RPM	220 CMM





Baker Brown



Topaz Gold



Oyster White



Lavender Brown



ENZO
Decorative Ceiling Fan



**SUPERIOR
PAINT FINISH**



**SLEEK &
STYLISH**

The Enzo offers a rich, exotic look that makes it an apt choice for trendy, modern apartments and offices. Wider, aerodynamically designed blades ensure higher airflow at lower speeds while its superior paint finish allows it to retain its classy appearance for a longer time. Like all fans in the decorative range, the Enzo has a powerful motor enhanced by high grade copper windings.

PRODUCT HIGHLIGHTS

- Incredibly Quiet · Bold Design For Modern Homes · Extremely Efficient · Exceptional Air Flow
- Superior Metallic Paint Finish · High Grade Copper · 2 Years Warranty



ITEM CODE	SWEEP	WATTAGE	SPEED	AIR DELIVERY
CFP 301324	600 mm	65W	850 RPM	105 CMM
SCFP 301336	900 mm	45W	450 RPM	140 CMM
SCFP 301348	1200 mm	50W	380 RPM	220 CMM





PRODUCT HIGHLIGHTS

- Incredibly Quiet · Elegant Design · Amazingly Efficient · Exceptional Air Flow
- High Grade Copper · Long Lasting Coat · 3 Years Warranty



AIR CREST

Classic Decorative Ceiling Fan

Make your summers cooler with the Air Crest decorative ceiling fan. The wide blades of this fan ensure that air is well distributed indoors. The Air Crest fan comes with a high-grade copper motor ensuring robust performance for a longer span. Designed for elegance, the Air Crest fan is available in attractive colors to blend well with any décor.

ITEM CODE	SWEEP	WATTAGE	SPEED	AIR DELIVERY
SCFP 501448	1200 mm	52W	350 RPM	210 CMM





VECTOR
Classic Decorative Ceiling Fan

ULTRA HIGH SPEED
400 RPM

HIGH GRADE COPPER

The Vector decorative ceiling fans will blow you away with their unmatched performance. With a powerful motor and aerodynamic blades, the fan promotes a wider conical spread of breeze to ensure air distribution in each and every corner of the room. Designed to perform optimally even at lower voltages, the Vector is a long-lasting robust fan.



Tangy Blue



Honey Mist



Smoke Brown

PRODUCT HIGHLIGHTS

- Incredibly Quiet · Elegant Design · Amazingly Efficient · Exceptional Air Flow
- Long Lasting Coat · 2 Years Warranty



ITEM CODE	SWEEP	WATTAGE	SPEED	AIR DELIVERY
SCFS 500848	1200 mm	52 W	400 RPM	215 CMM





Brown



Ivory



Smoke Brown



White

PRODUCT HIGHLIGHTS

- Incredibly Quiet · Bold Design For Modern Homes · Extremely Efficient · Exceptional Air Flow
- Long Lasting Coat · High Grade Copper · 2 Years Warranty



GATI DECO 400

Classic Decorative Ceiling Fan

True to its name, the Gati Deco 400 ceiling fan maximizes the airflow in your home with its robust motor and lightweight blades. As sophisticated as it looks, the fan performs efficiently even as it delivers ultra-high speed breeze. Simple yet elegant in looks, the Gati Deco 400 is enhanced with delicate metallic rings on the motor that adds poise and grace to the rooms.

ITEM CODE	SWEEP	WATTAGE	SPEED	AIR DELIVERY
SCFS 500348	1200 mm	50 W	400 RPM	210 CMM





Standard *ceiling fans*

THE CHARM OF SIMPLICITY

Experience the essence of reliable comfort with a Standard Ceiling Fan — a staple for any home. Designed for simplicity and efficiency, these fans are a testament to classic functionality. Their sleek, unassuming designs ensure that they blend seamlessly into any room, complementing a wide range of interior styles. Their straightforward, no-frills aesthetic speaks of a design philosophy where ease and practicality reign supreme.

A Goldmedal Standard Ceiling Fan is a powerhouse of performance, equipped with a durable, high-quality motor that guarantees consistent and effective air circulation. Reliable, efficient, and unobtrusively stylish, these fans are the quintessential choice for those who value enduring performance and understated elegance.

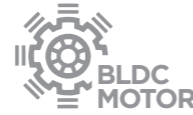

Ultra Performance BLDC MOTOR

Powered by a brushless DC motor, the Geo Fox ceiling fan operates quietly and efficiently, delivering high air volume while conserving energy.

Go green with the remote-controlled Geo Fox BLDC ceiling fans that can save up to 60% of energy consumption! Low in maintenance, the BLDC fan's motor is made of high-quality copper and world-class bearings that ensure longevity. The Geo Fox produces no heat and can perform seamlessly even at low voltage and during power fluctuations.

GEO FOX BLDC
Standard Ceiling Fan



PRODUCT HIGHLIGHTS

- Remote Control Operation For Fan On/Off & Speed Control · Rich & Trendy Looks
- 60% More Efficient Than Conventional Fans · Optimum Air Flow Even At Low Voltage
- No Humming Sound While Running On Inverter · 2 Years Warranty



ITEM CODE	SWEEP	WATTAGE	SPEED	AIR DELIVERY
CFS 500948	1200 mm	35 W	350 RPM	220 CMM





White



Brown



Ivory



Smoke Brown

MARUT BLDC
Standard Ceiling Fan



Embrace the future of home comfort with the Marut BLDC fan, where superior technology meets exquisite design. It is incredibly energy-efficient, with inverter compatibility, a 30W power draw, and Eco Active technology. Featuring a robust 1200mm sweep size, it delivers high performance. Available in elegant White, Ivory, and Brown, the Marut BLDC fan is a perfect fit for any room, from kitchens to home offices.

PRODUCT HIGHLIGHTS

- Wider Blade For Better Air Thrust · Amazingly Efficient · 60% More Efficient Than Conventional Fans
- Optimum Air Flow Even At Low Voltage · No Humming Sound While Running On Inverter



ITEM CODE	SWEEP	WATTAGE	SPEED	AIR DELIVERY
SCFS 500748	1200 mm	30 W	350 RPM	215 CMM

*Regulator is not supplied along with fan.





EN SAVER BLDC
Standard Ceiling Fan



Introducing the EN Saver BLDC Fan, a marvel in energy efficiency and inverter compatibility. Whisper-quiet at 65 dB, it ensures no humming on inverter power and offers superior air circulation with a 1200mm sweep. Its robust performance, even at 140V low voltages, comes from a pure copper wire motor. Eco Active technology reduces power consumption by 60%. Regulator-operated for convenience, available in White, Ivory, and Brown, it suits any room.



PRODUCT HIGHLIGHTS

- Wider Blade For Better Air Thrust • Amazingly Efficient • 60% More Efficient Than Conventional Fans
- Optimum Air Flow Even At Low Voltage • No Humming Sound While Running On Inverter



ITEM CODE	SWEEP	WATTAGE	SPEED	AIR DELIVERY
SCFS 502148	1200 mm	30 W	350 RPM	215 CMM

*Regulator is not supplied along with fan.





LEGACY 390
Standard Ceiling Fan

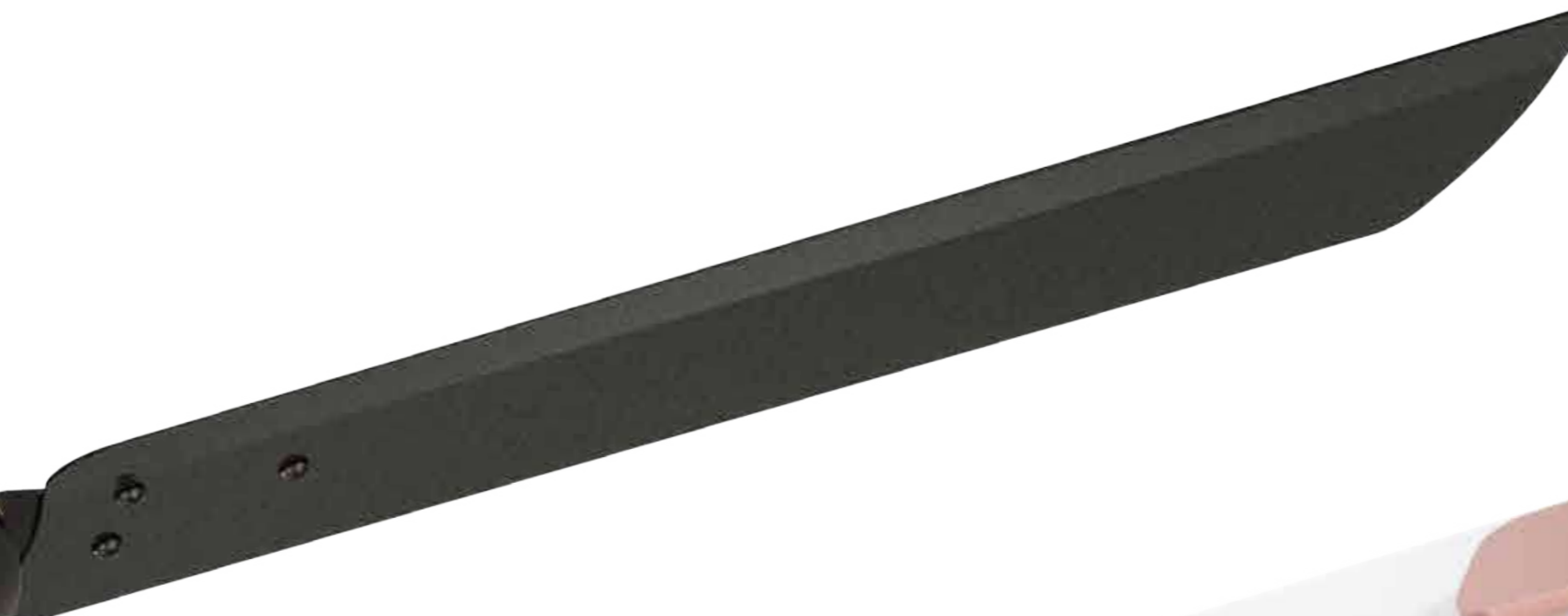

LEGACY PRIME
Decorative Ceiling Fan



Coming soon...



Pearl Ivory



Roast Brown



Matt White

PRODUCT HIGHLIGHTS

- Ultra High Speed · Clean Sophisticated Design · Amazingly Efficient
- Better Air Circulation · 2 Years Warranty



LEGACY 390
Standard Ceiling Fan

Truly living up to its name, the Legacy 390 is an elegantly designed, super-efficient fan! While wider blades promise better air distribution, the powerful motor of this fan ensures ultra-high speed up to 400 RPM. Available in Roast Brown, Matt White, and Pearl Ivory shades, the Legacy 390 blends smoothly with the aesthetics of your home.

ITEM CODE	SWEEP	WATTAGE	SPEED	AIR DELIVERY
SCFS 501348	1200 mm	52 W	400 RPM	225 CMM



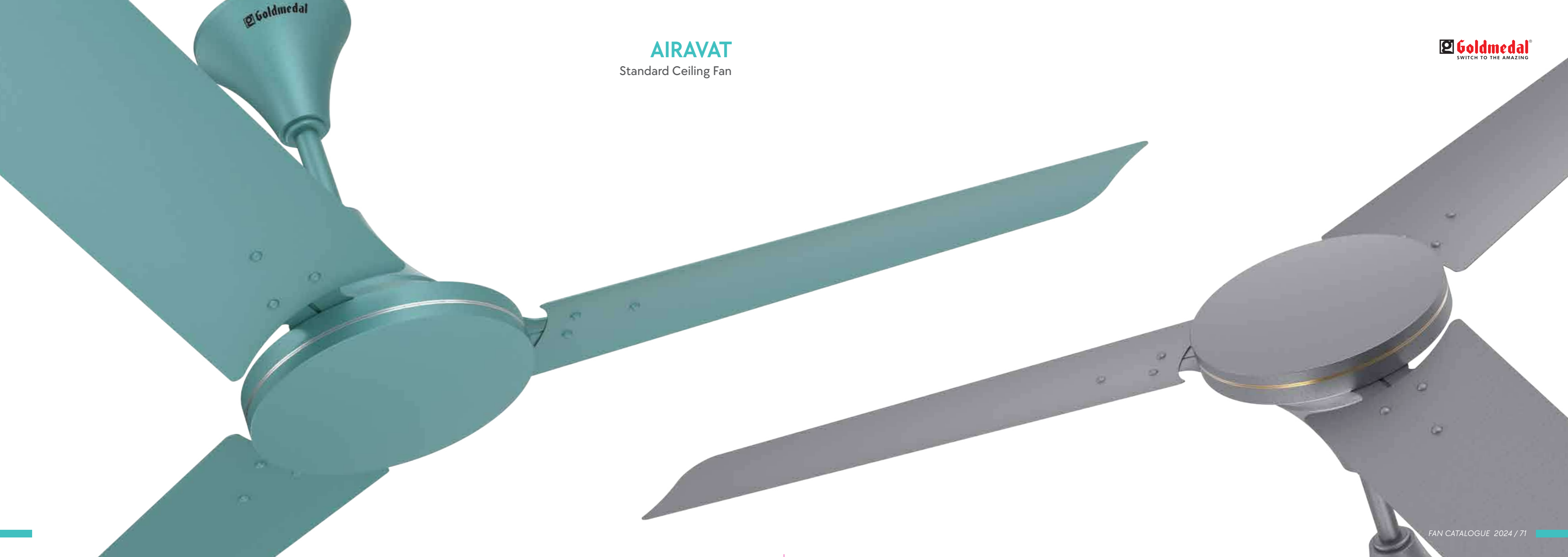

Goldmedal

AIRAVAT

Standard Ceiling Fan

Goldmedal
SWITCH TO THE AMAZING



AIRAVAT
Standard Ceiling Fan



True to its name, the Airavat ceiling fan comes with a powerful motor and efficient blades that ensure quick and efficient cooling of any room. The use of high grade copper windings, rotor, and stamping allows the Airavat to optimally function at high speeds for a very long time. The classic design makes it suitable for any kind of interior.



Matt Brown



Matt Gold



Matt Grey



Matt White



Matt Turquoise

PRODUCT HIGHLIGHTS

- Incredibly Quiet · Bold Design For Modern Homes · Extremely Efficient · Exceptional Air Flow
- Superior Metallic Paint Finish · 2+1 Years Extended Warranty



ITEM CODE	SWEEP	WATTAGE	SPEED	AIR DELIVERY
SCFS 501248	1200 mm	53W	350 RPM	220 CMM

*Extended warranty subject to registration





VELLFIRE
Standard Ceiling Fan



White



Brown



Ivory

VELLFIRE
Standard Ceiling Fan



The Vellfire fan weaves durability with elegance, boasting a robust full copper motor and ribbed aluminium blades to ensure efficiency. A decorative cup on the motor cover enhances its elegance, making it a stylish addition to any decor. Its premium powder coating ensures the fan's allure, and a 16-pole motor adds to its durability, promising whisper-quiet operation and steadfast reliability. The fan's sleek design is accentuated with decorative trims, adding a sophisticated touch to the surroundings.

PRODUCT HIGHLIGHTS

- Incredibly Quiet · Bold Design For Modern Homes · Extremely Efficient · Exceptional Air Flow
- Superior Metallic Paint Finish · 5 Years Warranty



ITEM CODE	SWEEP	WATTAGE	SPEED	AIR DELIVERY
SCFS 502048	1200 mm	53 W	350 RPM	220 CMM





STORM
Standard Ceiling Fan



True to its name, the Storm ceiling fan comes with a powerful motor and efficient blades that ensure quick and efficient cooling of any room. The use of high-grade copper windings, rotor, and stamping allows Storm to optimally function at high speeds for a very long time. The classic design makes it suitable for any kind of interior.



Brown



White



Ivory



Tangy Coffee

PRODUCT HIGHLIGHTS

- Ultra High Speed · Clean Sophisticated Design · Amazingly Efficient
- Better Air Circulation · 2 Years Warranty



ITEM CODE	SWEEP	WATTAGE	SPEED	AIR DELIVERY
SCFS 501148	1200 mm	53 W	380 RPM	220 CMM





VEGAH 400
Economy Ceiling Fan

**ULTRA
HIGH SPEED**
400 RPM

**HIGH AIR
DELIVERY**

The Vegah 400 ceiling fan is your true partner in helping you stay cool during summer. The fan is fitted with a powerful motor that performs optimally to ensure high air delivery. The wider blades ensure the air is distributed evenly throughout the room. Classy in looks, the Vegah 400 is available in five cool shades.

PRODUCT HIGHLIGHTS

- Ultra High Speed · Clean Sophisticated Design · Amazingly Efficient
- Better Air Circulation · 2 Years Warranty



ITEM CODE	SWEEP	WATTAGE	SPEED	AIR DELIVERY
SCFE 700148	1200 mm	50 W	400 RPM	210 CMM





VOLT 650
Economy Ceiling Fan



Experience the refreshing breeze with Volt 650. Its 900 mm aerodynamic blades ensure wide and efficient airflow at powerful 650 RPM. Silent yet potent, this fan features a double ball bearing design for smooth operation and longevity, all while consuming just 52 watts. Perfect for any room, the Volt 650 combines high-end engineering with energy efficiency, making it not just a fan, but a smart addition to your home.



White



Ivory



Brown



Blue

PRODUCT HIGHLIGHTS

- Ultra High Speed · Clean Sophisticated Design · Amazingly Efficient · Better Air Circulation
- High Grade Copper · 2 Years Warranty



ITEM CODE	SWEEP	WATTAGE	SPEED	AIR DELIVERY
SCFS 501936	900 mm	52 W	650 RPM	165 CMM



VOLT 400

Economy Ceiling Fan



PRODUCT HIGHLIGHTS

- Ultra High Speed
- Clean Sophisticated Design
- Amazingly Efficient
- Better Air Circulation
- High Grade Copper
- 2 Years Warranty



ITEM CODE	SWEEP	WATTAGE	SPEED	AIR DELIVERY
SCFS 501624	600 mm	65 W	850 RPM	100 CMM
SCFS 501636	900 mm	40 W	450 RPM	130 CMM
SCFS 501648	1200 mm	52 W	400 RPM	210 CMM



GATI 400 NEO

Economy Ceiling Fan



PRODUCT HIGHLIGHTS

- Ultra High Speed
- Clean Sophisticated Design
- Amazingly Efficient
- Better Air Circulation
- High Grade Copper
- 2 Years Warranty



ITEM CODE	SWEEP	WATTAGE	SPEED	AIR DELIVERY
SCFS 501824	600 mm	70W	850 RPM	110 CMM
SCFS 501836	900 mm	41W	450 RPM	130 CMM
SCFS 501848	1200 mm	50W	400 RPM	210 CMM
SCFS 501856	1400 mm	59W	310 RPM	245 CMM



AIR GT
Economy Ceiling Fan



- PRODUCT HIGHLIGHTS**
- Ultra High Speed
 - Clean Sophisticated Design
 - Amazingly Efficient
 - Better Air Circulation
 - High Grade Copper
 - 2 Years Warranty

ULTRA HIGH SPEED
400 RPM

HIGH GRADE COPPER

HIGH AIR DELIVERY
 NOISELESS OPERATION
 HIGH SPEED
 POWERFUL MOTOR
 LONG LASTING COAT

ITEM CODE	SWEEP	WATTAGE	SPEED	AIR DELIVERY
SCFE 700448	1200 mm	52 W	400 RPM	210 CMM

POWER SAVINGS GUIDE
MORE STARS
MORE SAVINGS

PREMIUM QUALITY GUARANTEED

G-BLISS
Economy Ceiling Fan



- PRODUCT HIGHLIGHTS**
- Ultra High Speed
 - Clean Sophisticated Design
 - Amazingly Efficient
 - Better Air Circulation
 - 2 Years Warranty

HIGH AIR DELIVERY

SUPERIOR PAINT FINISH

NOISELESS OPERATION
 DOUBLE BALL BEARING
 POWERFUL MOTOR
 LONG LASTING COAT

ITEM CODE	SWEEP	WATTAGE	SPEED	AIR DELIVERY
SCFE 700648	1200 mm	52 W	350 RPM	220 CMM

POWER SAVINGS GUIDE
MORE STARS
MORE SAVINGS

PREMIUM QUALITY GUARANTEED

Lifestyle & Personal *fans*



ELEVATE YOUR COMFORT

Transform your living spaces into havens of comfort and style with our exclusive collection of Lifestyle and Personal Fans. Dive into the future with our Bladeless Air Purifying Fans, designed to seamlessly blend advanced air purification technology with a sleek, modern aesthetic, ensuring your air is as clean as your style is sharp.

Experience elegance with our Lifestyle Pedestal Fans, where classic design meets modern functionality, offering unmatched stability, wide-angle oscillation, and a touch of sophistication to any room. For those on the move, Goldmedal's Personal Fans provide the ultimate solution in portable cooling, combining compact design with powerful airflow to keep you cool wherever you go. Whether you're looking to purify, stylize, or personalize your cooling experience, our range has you covered.



OXYRICH
Air Purifying Bladeless Fan

Experience the future of air purification with our sleek, bladeless fan, featuring ambient lighting. It is equipped with advanced HEPA filter technology, a user-friendly LED touch panel, and a magnetic remote for effortless control. Enjoy customizable oscillation angles and versatile modes, from Auto to Night, all in a chic, high-grade futuristic design. This fan not only purifies your air but also enhances your space with its mood-setting ambient light.

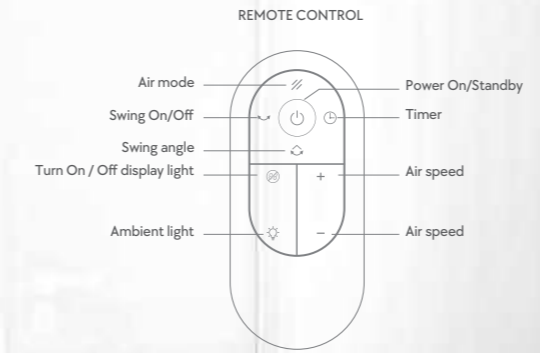
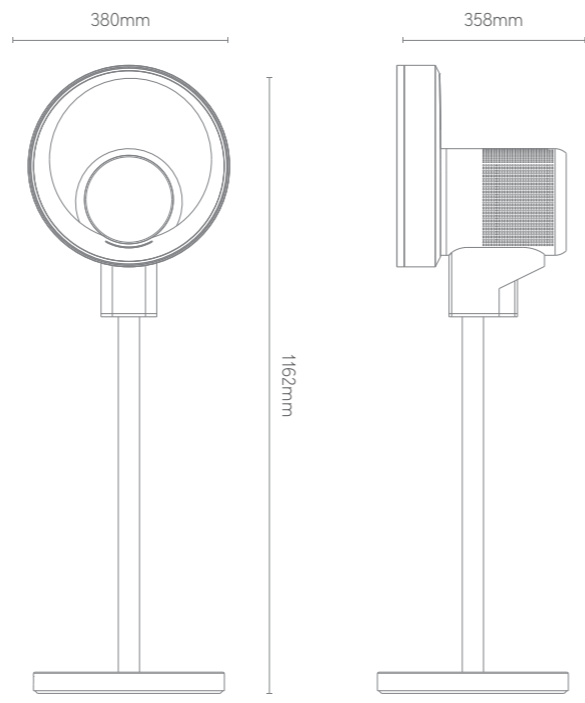

AIR INTAKE

- Installing the air filter
- 1) Rotate the air filter cover counterclockwise to remove the air filter cover.
 - 2) Put the air filter on the fan main body.
 - 3) The filter cover is loaded into the fan main body and fixed by clockwise rotation.

AIR FILTER COVER

AIR FILTER



PRODUCT HIGHLIGHTS

- Bladeless Fan With Air Purifying Technology
- Sleek Magnetic Remote Control
- LED Touch Control Panel
- Oscillation Angles 30°, 60°, 90° & 120°
- 4 Different Modes (Auto, Strong, Night, Breeze)
- Real-Time PM2.5 Level Display
- Up & Down Tilt Angle Up To 15°
- Off Timer Function (1 To 8 Hrs)





VISTA 360°
Lifestyle Pedestal Fan

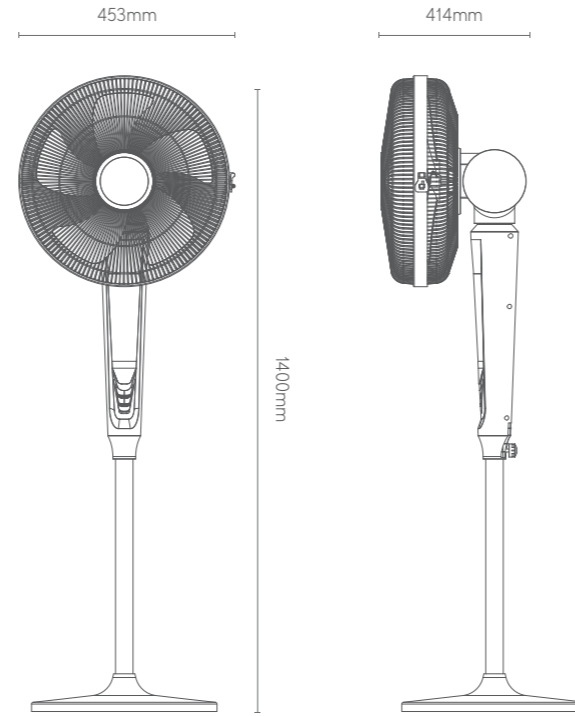

The Vista 360° pedestal fan is a marvel of modern design, blending high-grade plastics with a touch of copper elegance. Compact yet powerful with a 400 mm sweep, it offers a refreshing 360° breeze. Choose your comfort from multiple mode, and control it effortlessly with an IR remote. Its standout features include versatile oscillation options, a smart, auto-dimming LED display, and whisper-quiet operation. Plus, with its convenient timer settings, it's not just a fan – it's your personalized breeze crafted for comfort.

PRODUCT HIGHLIGHTS

- 3 Speed Setting With Normal / Breeze / Night Modes
- Automatic/Manual Horizontal & Manual Vertical Oscillation
- Remote Control · High Grade Copper
- Off Timer (1, 2, 4, 8 Hrs)



ITEM CODE	SWEEP	WATTAGE	SPEED	AIR DELIVERY
PFP 300216	400 mm	53 W	1158 RPM	65 CMM



White





SPEEDO-X
Lifestyle Pedestal Fan

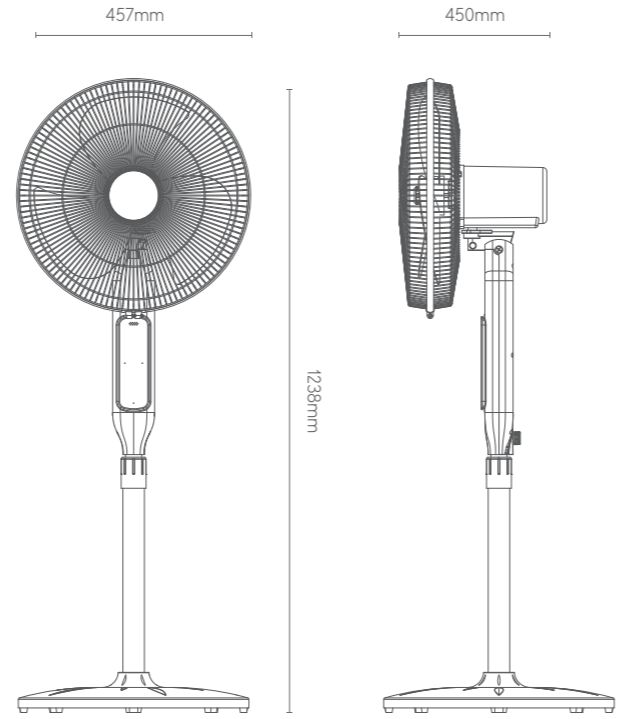

Welcome to the future of cooling with Speedo-X! This fan boasts a high-grade plastic body and a 400 mm sweep for optimal air delivery thanks to its durable ABS-grade blades. It's smart too, with self-overheat protection and an LED touch panel. Control is easy with its handy remote and three-speed settings. Adjustable in height, it also features a timer. High-speed, aerodynamic, and easy to install, the Speedo-X is your answer to advanced and efficient cooling.

PRODUCT HIGHLIGHTS

- ABS Grade Blade For Better Air Delivery & Long Life
- Self-protection When Over Heated
- LED Indicator Display With Touch Panel
- Remote Control
- 6 Speed Setting With Mode Normal/Natural/Sleep (1, 2, 3 Air Circulation & 4, 5, 6 High Speed)
- Telescopic Height Adjustment
- Off Timer (0.5 To 7.5 Hrs)

ENERGY EFFICIENT
 AERODYNAMIC BLADE
 POWERFUL MOTOR
 HIGH AIR DELIVERY
 3 SPEED CONTROLLER

ITEM CODE	SWEEP	WATTAGE	SPEED	AIR DELIVERY
PFP 300316	400 mm	130 W	2350 RPM	100 CMM



White





GRACE
Lifestyle Pedestal Fan

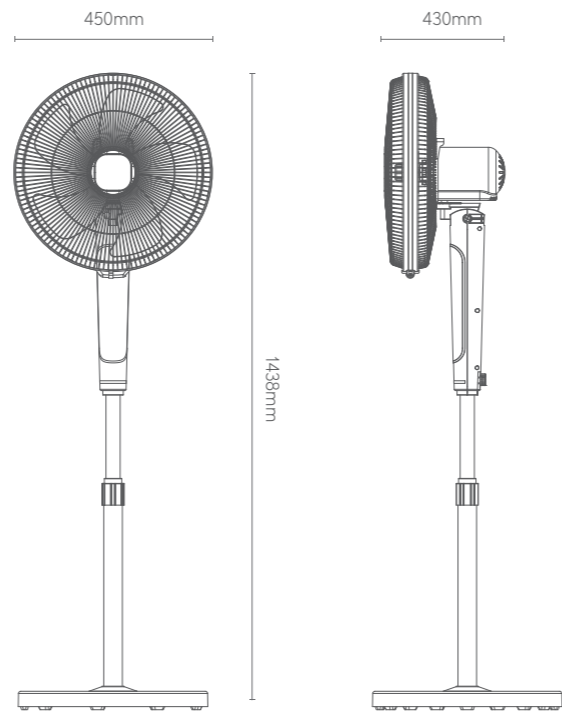

A marvel of modern engineering, the Grace pedestal fan, encased in a high-grade plastic body, boasts a sweeping 400 mm span and a powerful motor. Resting on a broad base for stability, its aerodynamic blade design and wide-angle horizontal oscillation ensure optimal air delivery. Featuring a temperature sensor with a real-time display, a touch panel, and a remote control, this fan is the pinnacle of convenience. Unique features include customizable timers, 12-speed settings, and adjustable height. Easy to install, it combines style, efficiency, and durability.

PRODUCT HIGHLIGHTS

- Wide Angle Horizontal Oscillation
- AS Grade Blade For Long Life
- 5 Leaf Blade For Better Air Delivery
- Synchronous Motor For Oscillation
- Real-time Temperature Display
- Touch Panel & Remote Control
- Off Timer Function (1/2/3/4/5/6/7/8/9 Hrs)
- Telescopic Height Adjustment



ITEM CODE	SWEEP	WATTAGE	SPEED	AIR DELIVERY
PPF 300716	400 mm	56 W	1230 RPM	75 CMM



Black Gold





FUSION
Lifestyle Pedestal Fan

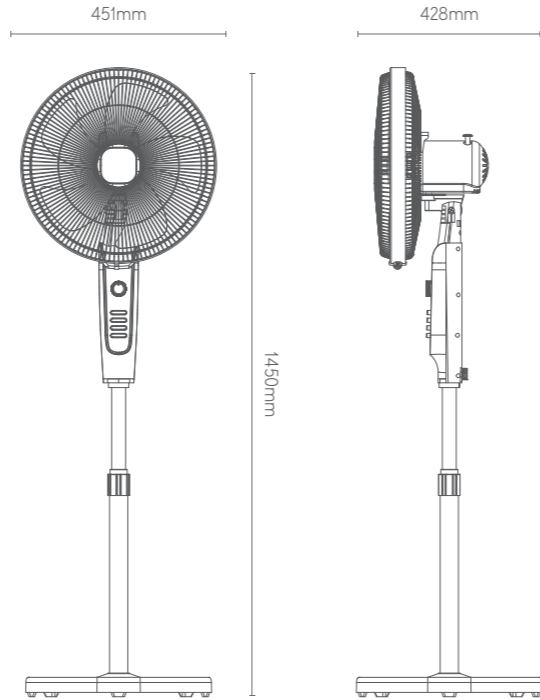

A compact powerhouse with a high-grade plastic body and a 400 mm sweep, the Fusion pedestal fan offers a 3-speed controller and aerodynamic blades for superior airflow. Easy to install, it features wide-angle oscillation and durable AS-grade blades. Equipped with a self-protecting, high-grade copper synchronous motor, it includes a handy manual timer and telescopic height adjustment. Enjoy high air delivery and whisper-quiet operation, all driven by a powerful motor.

PRODUCT HIGHLIGHTS

- Wide Angle Horizontal Oscillation
- AS Grade Blade For Long Life
- 5 Leaf Blade For Better Air Delivery
- Synchronous Motor For Oscillation
- Self-protection When Over Heated
- High Grade Copper
- 10/20/30/40/50/60 Mins Manual Timer Function
- Telescopic Height Adjustment



ITEM CODE	SWEEP	WATTAGE	SPEED	AIR DELIVERY
PFP 300616	400 mm	53 W	1245 RPM	75 CMM



White Rose Gold





TRICOOL
Lifestyle Portable Fan



Don't miss out on Tricool, a multipurpose 3-in-1 electric fan that can be used as a pedestal, wall, and table fan. The high-speed performance fan is supported by aerodynamic blades for noiseless operation. Brilliantly designed, the energy-efficient Tricool fans are powered by a copper motor for improved air distribution.

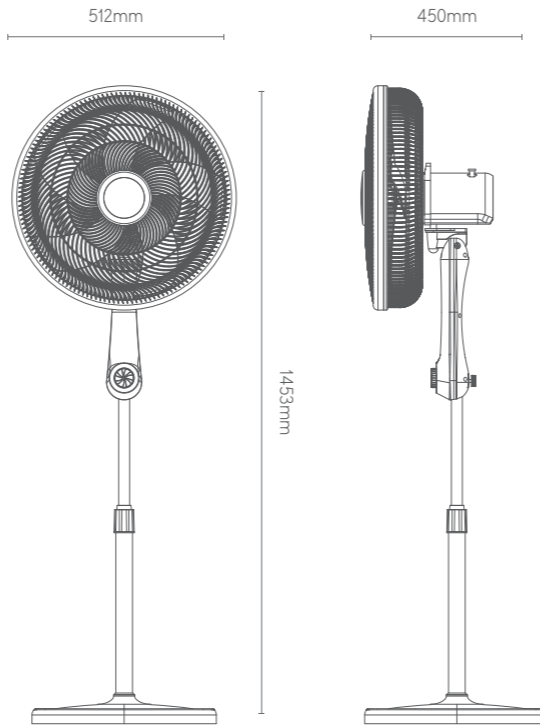

PRODUCT HIGHLIGHTS

- ABS Plastic Body · Easily Washable & Cleanable
- 3 In 1 (Pedestal, Wall & Table) · Plastic Blades For Silent Operation
- Composition 60% Plastic & 40% Metal · Jerk Free Oscillation
- Telescopic Height Adjustment · High Grade Copper



ITEM CODE	SWEEP	WATTAGE	SPEED	AIR DELIVERY
LFP 800118	450 mm	80 W	1350 RPM	105 CMM



Black Red





AIR FIESTA
Lifestyle Pedestal Fan



The Air Fiesta fan brings a fusion of style and efficiency to your space. Its high-grade plastic and metallic aluminium blades deliver silent, efficient airflow. With a 450 mm sweep and 1350 RPM speed, coupled with an aerodynamic design, it ensures powerful air delivery. Unique features include a slot for an air freshener pouch, jerk-free oscillation, and easy height adjustment. The durable copper motor, thermal protection, and four-speed control offer reliability and versatility in a sleek, easy-to-maintain design.

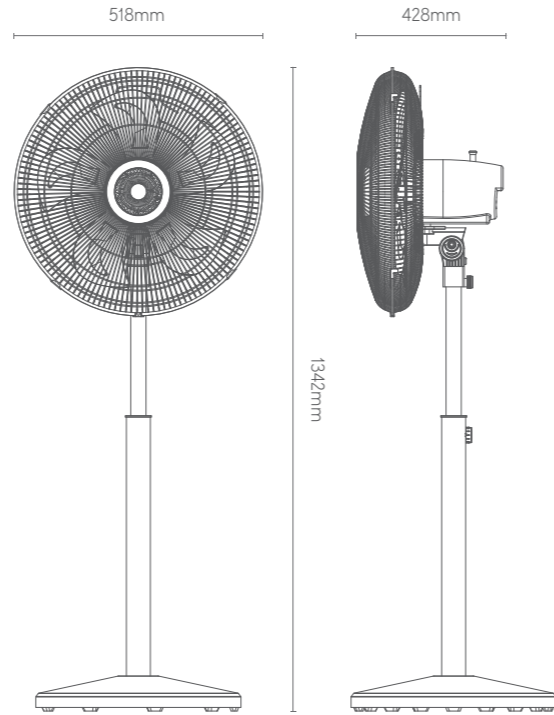

PRODUCT HIGHLIGHTS

- High Performance Motor • 5 Aluminum Blades With Metallic Finish
- Jerk Free Oscillation • Thermal Overload Protection
- Smooth Tilttable Neck Movement • Silent Operation
- Slot For Air Freshener



ITEM CODE	SWEEP	WATTAGE	SPEED	AIR DELIVERY
PFP 300118	450 mm	90 W	1350 RPM	100 CMM



Bronze Copper



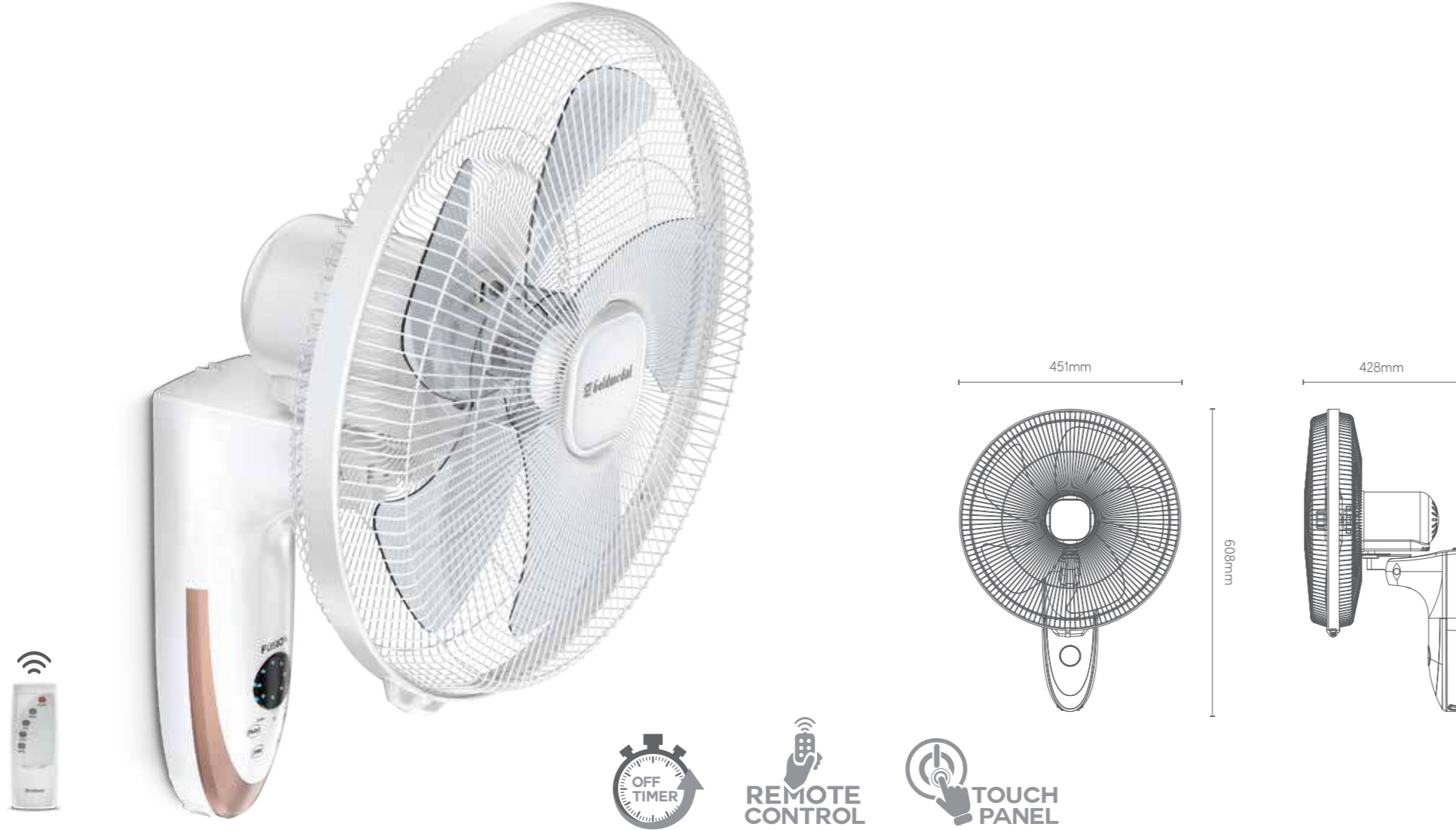

FUSION DG
Lifestyle Wall Fan



Presenting the Fusion DG wall fan, a sleek, high-grade plastic masterpiece with a 400 mm sweep. It offers whisper-quiet, energy-efficient performance, and superior air delivery, thanks to its aerodynamic blades and powerful motor. Features include wide-angle oscillation, self-protection from overheating, a touch panel with remote control, and a convenient timer. Easy to install, this fan is a perfect blend of modern design and functionality.

PRODUCT HIGHLIGHTS

- Wide Angle Horizontal Oscillation
- AS Grade Blade For Better Air Delivery & Long Life
- Self-protection When Over Heated • High Grade Copper
- Touch Panel & Remote Control • Off Timer (7.5 Hrs)



White Rose Gold

ITEM CODE	SWEEP	WATTAGE	SPEED	AIR DELIVERY
WFP 200416	400 mm	68 W	1350 RPM	75 CMM



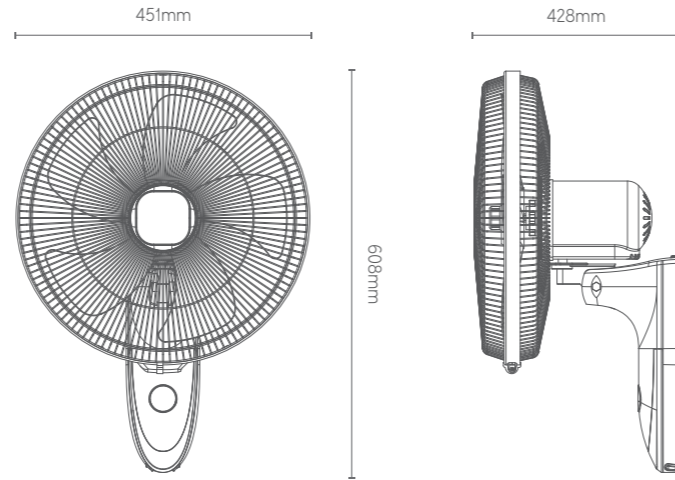

NOISELESS OPERATION
HIGH AIR DELIVERY

Engineered for excellence, the Fusion wall fan features a powerful, high-grade copper motor and an aerodynamic AS-grade blade design, ensuring optimal air delivery and enduring performance. With its easy installation, three-speed control, and wide-angle horizontal oscillation, it brings a breeze of convenience to any room. Experience tranquility with its noiseless operation and trust in its self-protection feature during overheating.

FUSION
Lifestyle Wall Fan

PRODUCT HIGHLIGHTS

- Wide Angle Horizontal Oscillation
- AS Grade Blade For Better Air Delivery & Long Life
- Self-protection When Over Heated • High Grade Copper
- Synchronous motor For oscillation

AERODYNAMIC BLADE
 ENERGY EFFICIENT
 3 SPEED CONTROLLER
 EASY INSTALLATION
 POWERFUL MOTOR



White Rose Gold

ITEM CODE	SWEEP	WATTAGE	SPEED	AIR DELIVERY
WFP 200316	400 mm	53 W	1245 RPM	75 CMM



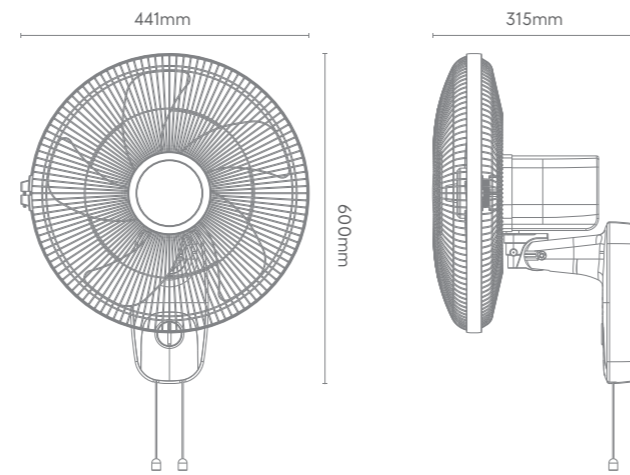

There is so much to adore about the Adora wall fan. From its whisper-quiet performance, self lubricating motor to its powerful and efficient 5 leaf SAN blade design, Adora is the wall fan that you need. It has a double ring metal grill for sturdy operation and wide-sweep oscillation for maximum air delivery. It is a free-neck device, which allows easy vertical adjustment. The adorable Adora is available in a classical single grey colour.

ADORA
Portable Wall Fan

PRODUCT HIGHLIGHTS

- Self Lubricating Motor · Wide-sweep Oscillation
- Powerful & Efficient · Double Ring Metal Grill · Free Neck Device
- High Grade Material With 5 Leaf SAN Blades



ITEM CODE	SWEEP	WATTAGE	SPEED	AIR DELIVERY
WFP 200716	400 mm	55 W	1200 RPM	90 CMM



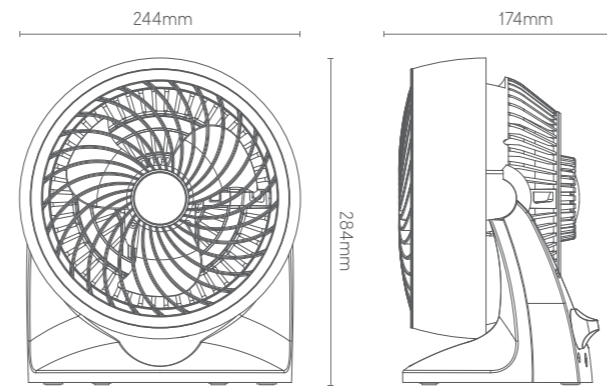

3 SPEED CONTROLLER

I FRESH
Personal Fan

Experience a breeze of fresh air without disturbances with the I-Fresh portable fan. Designed for life on the go, it's perfect for bedrooms, desktops, strollers, or outdoor adventures. Engineered with a quiet yet powerful aerodynamic motor, it promises a robust airflow to keep you cool, while safeguarding your little one's fingers. Easy to install on any surface, this fan boasts a sleek design with a metallic ring and is available in two chic colours.



Black



White

PRODUCT HIGHLIGHTS

- High Grade Copper · Desk And Wall Mountable
- Powerful Motor · Energy Efficient
- Aerodynamically Designed Blades · Attractive Colour Combination

ENERGY EFFICIENT
 HIGH SPEED
 EASY INSTALLATION
 POWERFUL MOTOR
 NOISELESS OPERATION
 EASY CLEANING & MAINTENANCE

ITEM CODE	SWEEP	WATTAGE	SPEED	AIR DELIVERY
PCS 650409	230 mm	28 W	2200 RPM	25 CMM





TRISTAR
Personal Fan

This power-packed mini personal fan is everything you will ever need in a fan. It is compact, energy-efficient and delivers air at high speed, giving you instant relief from the hot weather. Longevity is guaranteed as the Tristar is made with high-grade copper and coated with metallic finish. Available in cool Black Yellow and White Grey colour combinations, the Tristar is designed to make a style statement!

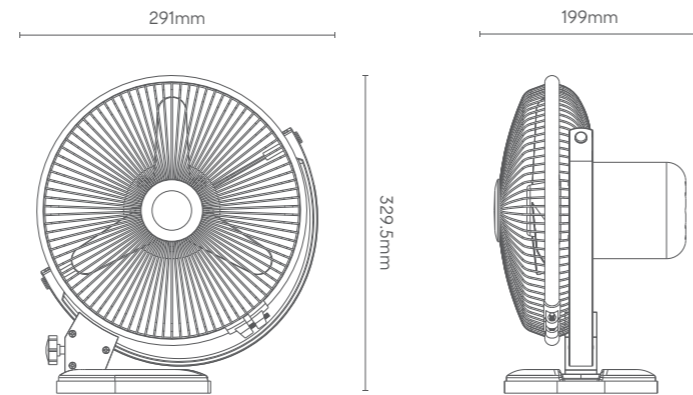

White Grey



Black Yellow

PRODUCT HIGHLIGHTS

- Energy Efficient • Powder Coated Metallic Finish • Powerful Motor
- High Grade Copper • Compact Design



ITEM CODE	SWEEP	WATTAGE	SPEED	AIR DELIVERY
PCS 650909	225mm	45 W	2200 RPM	25 CMM



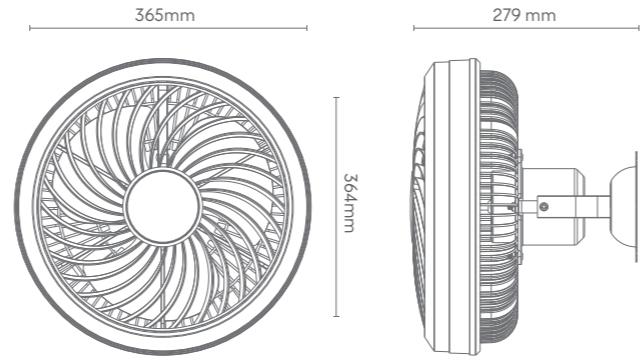

ASTOR
Cabin Fan

The Astor cabin fans can be a rich addition to your homes and offices. This compact and sturdy fan comes with a powerful motor to provide breezy and cool air. The Astor fans can move flexibly for better air delivery while their visually appealing protective grill keeps the user secure from any accidental touch. Easy to carry and fix, the Astor fans can be easily installed in rooms or cabins that demand quick cooling.



White Grey

PRODUCT HIGHLIGHTS

- PP Blades · Incredibly Quiet · High Air Delivery
- Amazingly Stylish · Innovative & Contemporary Design

DOUBLE BALL BEARING
 HIGH SPEED
 POWERFUL MOTOR
 HIGH AIR DELIVERY
 SUPERIOR PAINT FINISH

ITEM CODE	SWEEP	WATTAGE	SPEED	AIR DELIVERY
PCS 650212	300mm	75 W	2200 RPM	60 CMM



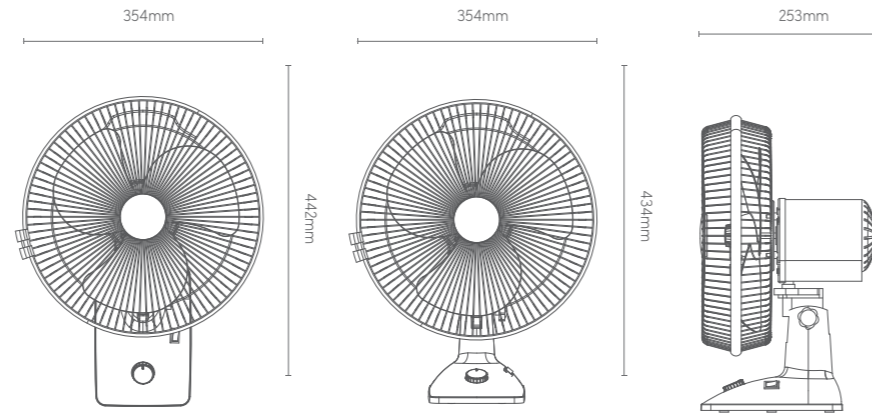
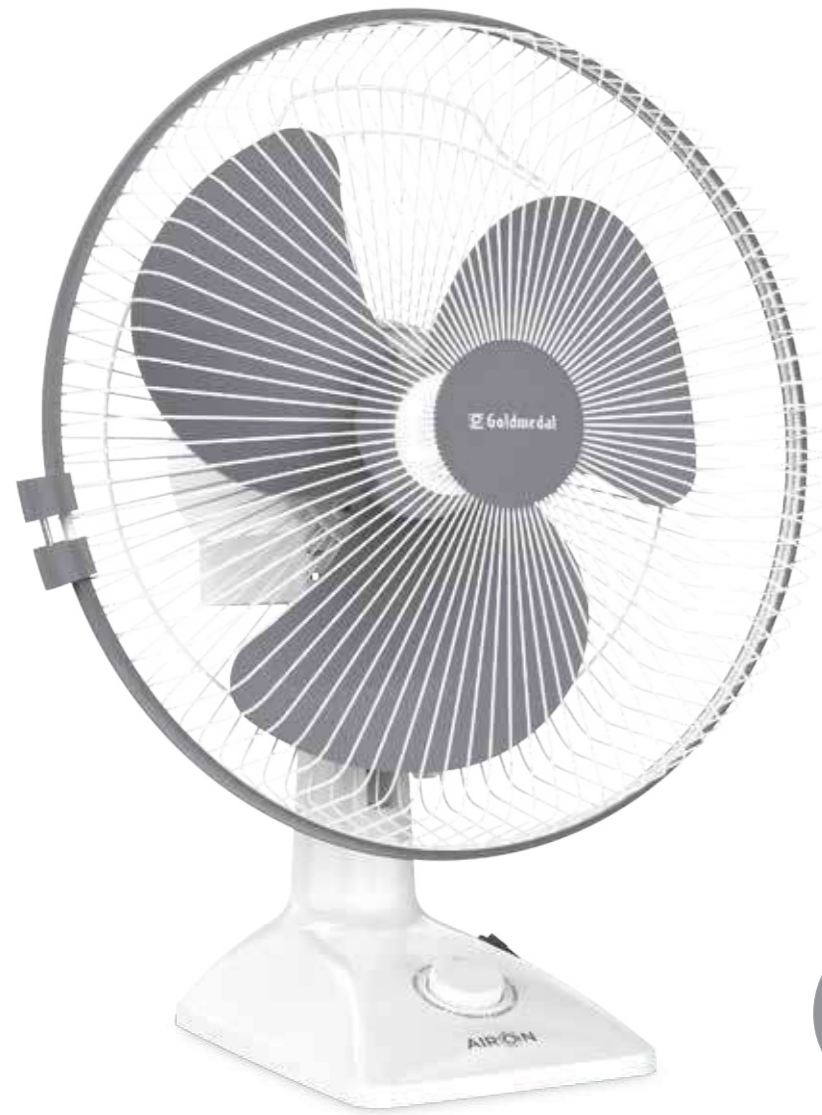

AIR ON
Personal Fan

Meet the Air ON personal fan – your versatile cooling solution. Lightweight and portable, it's designed to oscillate gracefully, delivering a cool breeze across any room. With a robust copper motor turning the aerodynamic blades at a brisk 2500 RPM, enjoy a refreshing 80-degree sweep of high air delivery at any time. Its three tilt angles and smooth oscillation ensure that every corner feels the chill.



White



White Grey

PRODUCT HIGHLIGHTS

- High Grade Copper • Desk and Wall Mountable • Powerful Motor • Energy Efficient
- Aerodynamically Designed Blades • Attractive Colour Combination

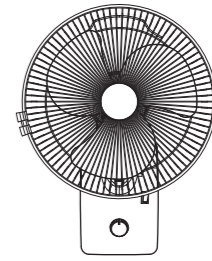

WALL FAN

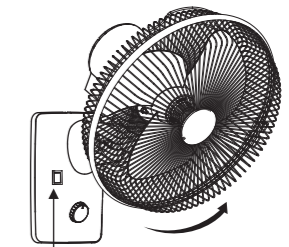

OSCILLATION SWITCH

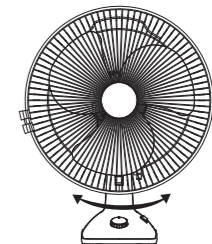
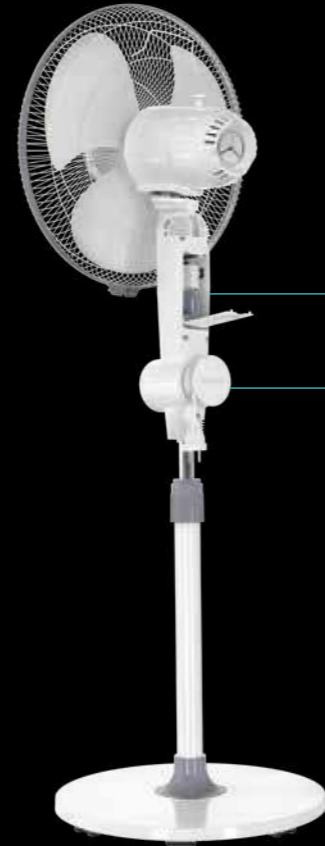

TABLE FAN

ITEM CODE	SWEEP	WATTAGE	SPEED	AIR DELIVERY
PCS 650509	230 mm	50 W	2500 RPM	30 CMM



Introducing
STORM HS & STORM
Table , Pedestal & Wall Fan



SLOT FOR MOSQUITO
REPELLENT



A CORD WINDER FOR
SAFETY AND EASE OF USE





STORM HS
Pedestal Fan

The Storm HS pedestal fan stands out as an essential household item for the warmer months, blending super-stylish design with efficiency and user-friendly operation. Its portability and high-speed airflow, powered by a robust motor, ensure cool and comfortable environments. Beyond its aesthetic appeal, this fan is built for lasting performance and includes a cord winder for added safety and convenience. Additionally, it features mosquito repellent technology, making it a versatile choice for any home.

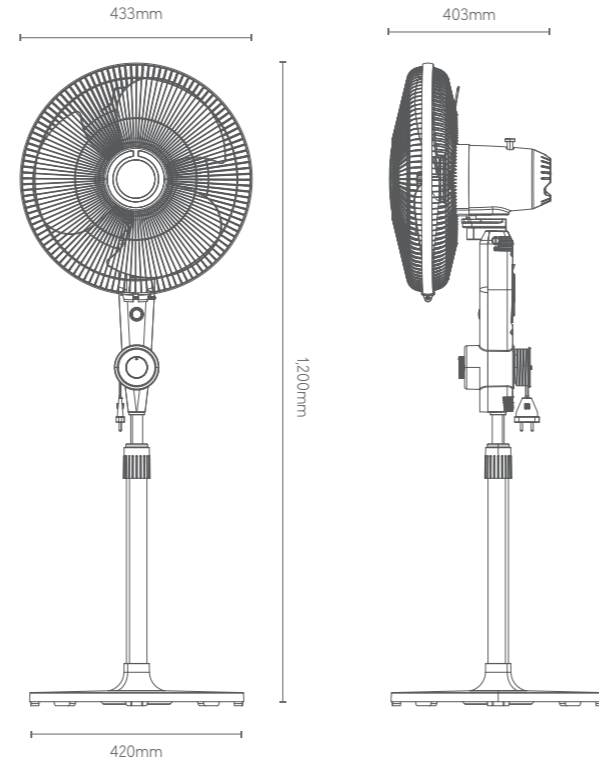

SLOT FOR MOSQUITO REPELLENT



A CORD WINDER FOR SAFETY AND EASE OF USE

PRODUCT HIGHLIGHTS

- Fights Mosquitoes With Rapid Strike Technology · A Cord Winder For Safety And Ease Of Use
- Aerodynamic Blade For Better Air Delivery & Long Life · Thermo Cut-off Protection
- High Grade Copper · Corrosion Resistant Powder Coated Metal Guards
- Telescopic Height Adjustment



ITEM CODE	SWEEP	WATTAGE	SPEED	AIR DELIVERY
PFS 403616	400 mm	110 W	2200 RPM	100 CMM



White Grey



Turquoise White





STORM
Pedestal Fan

The Storm pedestal fan, ergonomically designed and lightweight, is equipped with standout features including mosquito repellent technology. Its PP blades ensure optimal air delivery, while the jerk free motor offers a blend of power and efficiency. With corrosion-resistant, powder-coated metal guards, it promises lasting durability. Perfect for overcoming the Indian summer heat with flair, the Storm fan is the ultimate choice for stylish and effective cooling.

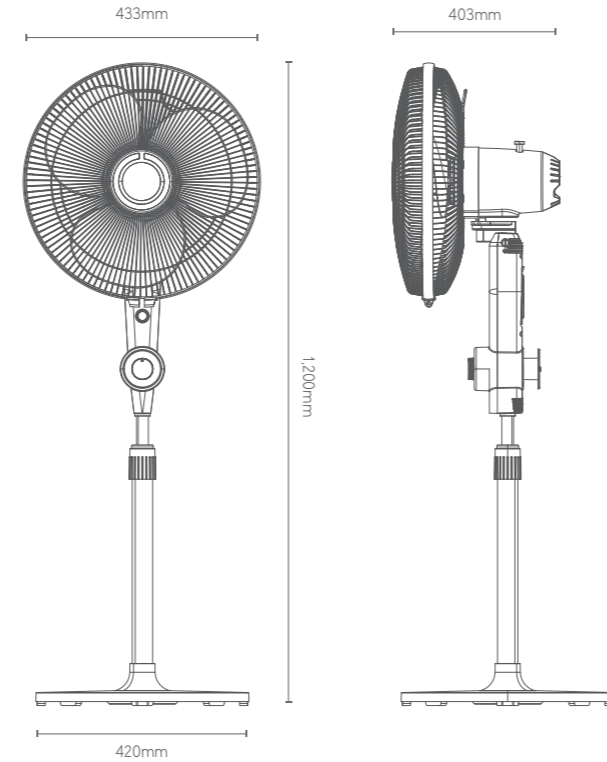

SLOT FOR MOSQUITO REPELLENT



A CORD WINDER FOR SAFETY AND EASE OF USE

PRODUCT HIGHLIGHTS

- Fights Mosquitoes With Rapid Strike Technology · A Cord Winder For Safety And Ease Of Use
- Aerodynamic Blade For Better Air Delivery & Long Life · Jerk Free Oscillation
- High Grade Copper · Corrosion Resistant Powder Coated Metal Guards
- Telescopic Height Adjustment



ITEM CODE	SWEEP	WATTAGE	SPEED	AIR DELIVERY
PFS 403716	400 mm	55 W	1350 RPM	75 CMM



White Grey



Turquoise White



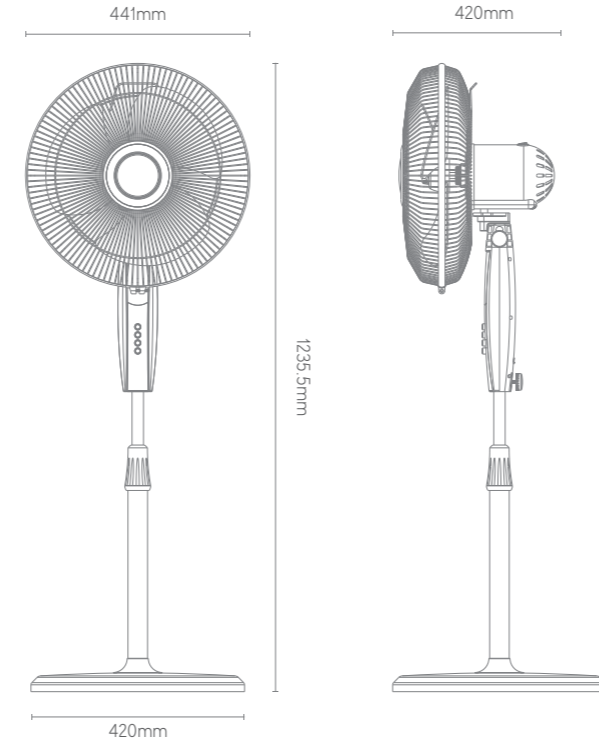

NORA
Pedestal Fan

The Nora is a lightweight and ergonomically designed fan packed with some great features. It has PP blades for better air delivery, a synchronous motor for powerful yet efficient performance and corrosion resistant powder-coated metal guards for longevity. There is no better fan to beat the Indian summer heat in style than the Nora pedestal fan!

PRODUCT HIGHLIGHTS

- PP Decorative Blades · Incredibly Quiet · High Air Delivery · Amazingly Stylish
- Innovative & Contemporary Design



ITEM CODE	SWEEP	WATTAGE	SPEED	AIR DELIVERY
PFS 403516	400 mm	110 W	2200 RPM	100 CMM



White Sea Blue

White

White Maroon



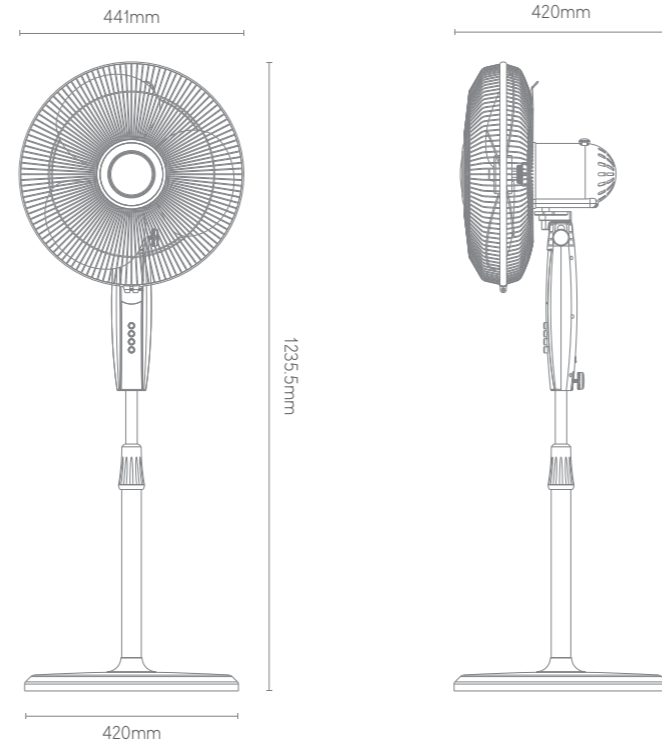

ERICA
Pedestal Fan

Powerful, quiet, and extremely energy efficient, the Erica pedestal fan is a must-have in every Indian home and office. With its smooth oscillation, multiple speed options and telescopic height adjustment, the Erica is an ideal solution when you feel the need for a cool breeze! Available in three attractive colour options, the Erica pedestal fans are incredibly stylish and cool!

PRODUCT HIGHLIGHTS

- Plastic Blades · Silent Operation · Jerk-Free Oscillation · High Grade Copper
- Powder Coated Metal Guards · Telescopic Height Adjustment



ITEM CODE	SWEEP	WATTAGE	SPEED	AIR DELIVERY
PFS 400516	400 mm	55 W	1350 RPM	75 CMM



White Sea Blue

White

Black Grey



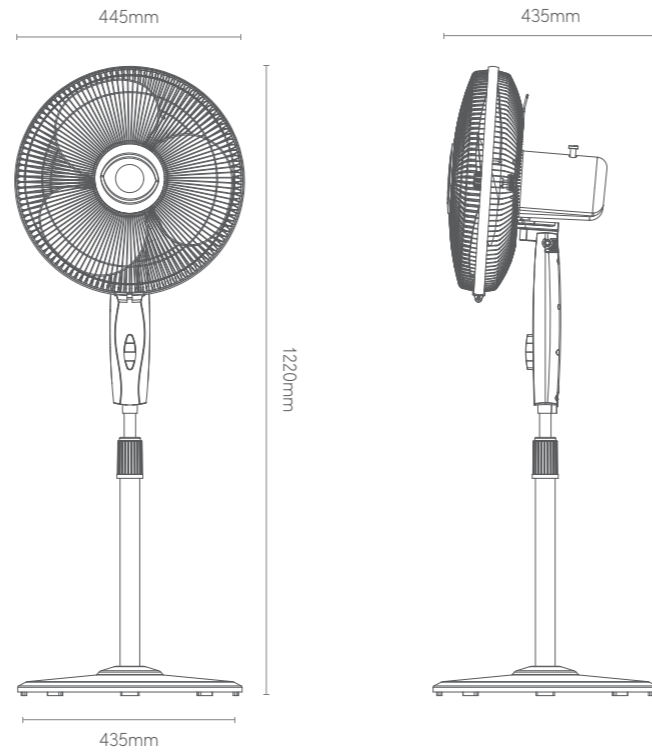

DYNO PRO
Pedestal Fan

Super-stylish, efficient, and easy to operate is what makes the Dyno Pro pedestal fan a must for every household during the warmer months. Easily portable, this fan delivers high speed breeze to keep you cool and comfortable. The Dyno Pro fan is not only aesthetically appealing but also designed to perform seamlessly for years.

PRODUCT HIGHLIGHTS

- High Grade Copper · Jerk Free Oscillation · Telescopic Height Adjustment
- Plastic Blades With Silent Operation · Corrosion Resistant Powder Coated Metal Guards



ITEM CODE	SWEEP	WATTAGE	SPEED	AIR DELIVERY
PFS 400416	400 mm	110 W	2200 RPM	100 CMM



White

Turquoise White



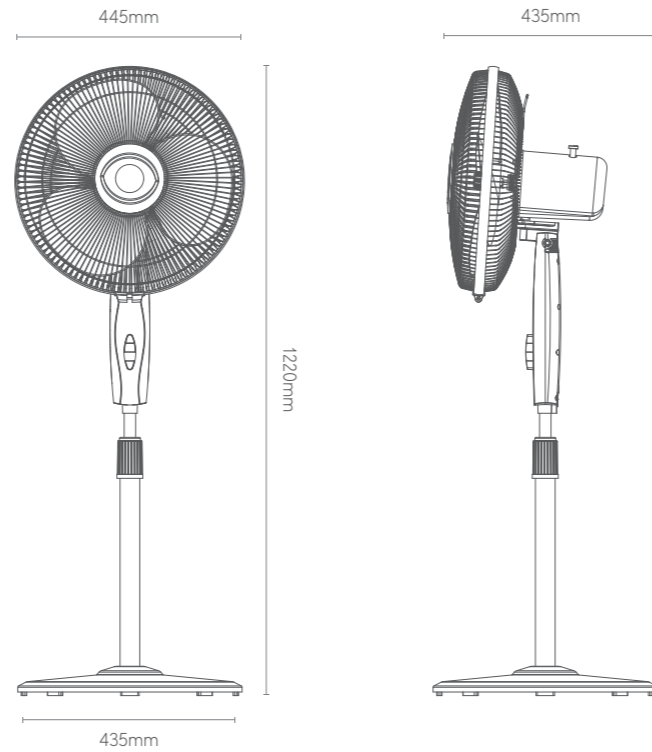

PRODUCT HIGHLIGHTS

- High Grade Copper • Jerk Free Oscillation
- Telescopic Height Adjustment • Plastic Blades With Silent Operation
- Corrosion Resistant Powder Coated Metal Guards

ENERGY EFFICIENT
 3 SPEED CONTROLLER
 BROAD BASE
 AERODYNAMIC BLADE ANGLES
 HIGH GRADE SILICON STEEL



Turquoise White Red Black Turquoise Black

ITEM CODE	SWEEP	WATTAGE	SPEED	AIR DELIVERY
PFS 400716	400 mm	55 W	1350 RPM	75 CMM

DYNO
Pedestal Fan

Keep your homes cool with the ultra-quiet, strong, and energy-efficient Dyno pedestal fans. These fans perform without any hitch thanks to their smooth oscillation and numerous speed settings along with head and height position adjustments. The Dyno fans are not only sturdy but also fashionable and are available in a variety of attractive colors.





FALCON | FALCON PRO
Pedestal Fan



If you're looking for a sophisticated, stylish, and modern pedestal fan for your home, the Falcon and Falcon Pro pedestal fans are undoubtedly the best choice. These wide-base fans offer jerk-free oscillation and super smooth operation. The Falcon fans also feature aerodynamic ABS blades that offer superior air delivery and three modes of operation for added convenience. Additionally, the Falcon Pro includes a tilt option that ensures effective cooling wherever you need it.

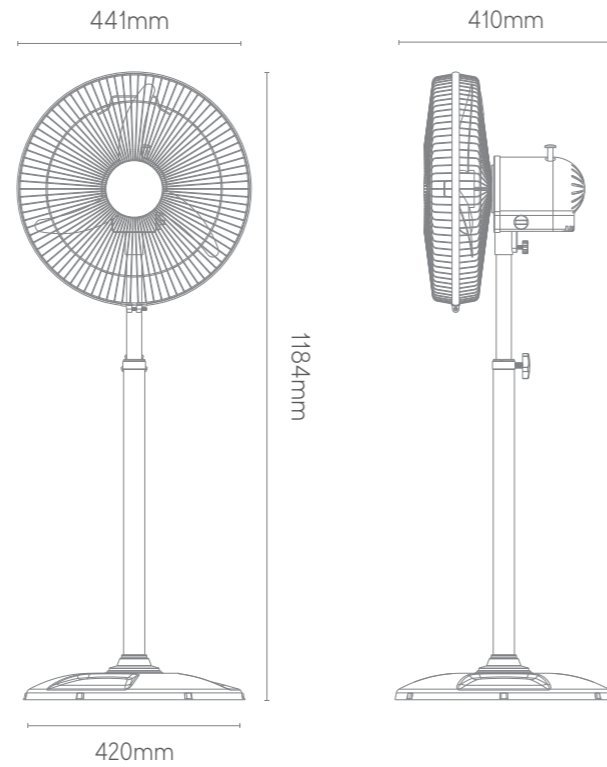

PRODUCT HIGHLIGHTS

- Rich & Modern Style · Jerk-free Oscillation & Smooth functioning
- Powder Coated Guards · Smooth Tiltable Neck Movement in Falcon Pro



ITEM CODE	SWEEP	WATTAGE	SPEED	AIR DELIVERY
FFS 550316	400 mm	105 W	2100 RPM	125 CMM
PFS400816	400 mm	105 W	2100 RPM	125 CMM



Black Silver

Black Yellow





G-EXPRESS
Pedestal Fan

Comfort is guaranteed when you have the G-Express pedestal fans that deliver super cool breeze by your side. These pedestal fans are supported by a super quiet motor and aluminum blades which make the fans rust-free thus improving their performance and longevity. G-Express fans can also be vertically adjusted up to 30 degrees in addition to 90-degree oscillation for better air delivery.

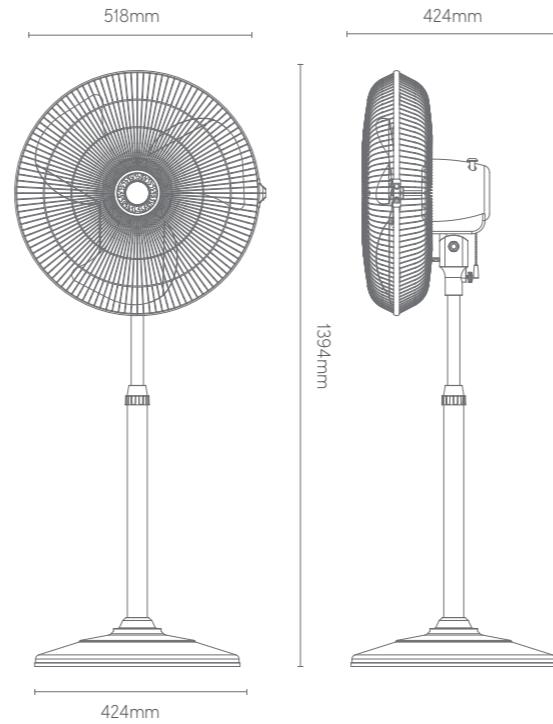

PRODUCT HIGHLIGHTS

- Aluminium Blades • Silent Jerk Free Operation
- Telescopic Height Adjustment • High Grade Copper
- Powder Coated Metal Guards



ITEM CODE	SWEEP	WATTAGE	SPEED	AIR DELIVERY
FFS 550618	450 mm	90 W	1350 RPM	100 CMM



Black Silver

Black



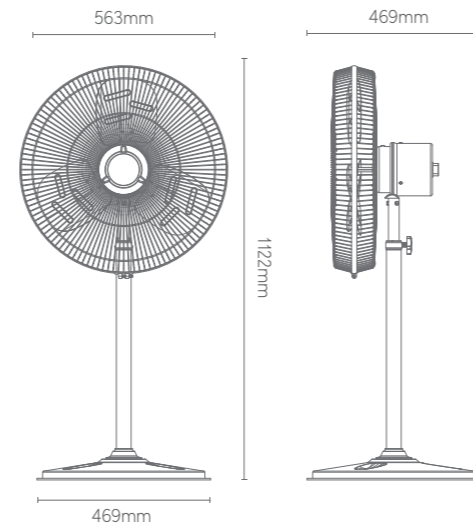

TURBO MAXX | TURBO STAR

Pedestal Fan

In search of a heavy-duty yet stylish pedestal fan? Look no further. The Turbo Maxx and Turbo Star are modern and sturdy pedestal fans with iron cast base that keeps the fans stable as it deliver high-speed air! The aerodynamic metal blades are coated with corrosion-resistant powder so that they last longer. The Turbo Maxx and Turbo Star is available with three modes of operation for added convenience.

PRODUCT HIGHLIGHTS

- Modern Design · Powder Coated Guards · Sturdy Iron Cast Base
- Aerodynamic Metal Blades · Three Modes of Operation
- 100% Copper Winding



ITEM CODE	ITEM NAME	SWEEP	WATTAGE	SPEED	AIR DELIVERY
FFS 550220	TURBO MAXX	500 mm	135 W	1350 RPM	120 CMM
PFS 400116	TURBO STAR	500 mm	135 W	1350 RPM	120 CMM



Grey



Black



Axial & Ventilation *exhaust fans*



FRESHNESS IN EVERY CORNER

Discover the ultimate air management solution with Axial and Ventilation Exhaust Fans. These fans are a perfect blend of technology and performance, transforming any space into an oasis of fresh, clean air. Ideal for both commercial and residential spaces, their sleek design and eco-friendly technology ensure a harmonious blend of style and sustainability.

Every breath is a step toward a healthier, more comfortable life with these advanced fans. They not only improve air circulation but also silently purify and rejuvenate your space, promising an effortless enhancement to your environment.



FROST | FROST PRIME

Axial Exhaust Fan

Boost your interiors with Frost and Frost Prime, efficient and ultra-modern axial fans that offer powerful air suction for clean and fresh air delivery. The Frost Prime comes with LED lights on the sides rendering it an uber-cool look. True to their name, the Frost fans provide a constant flow of fresh air circulation in the room.

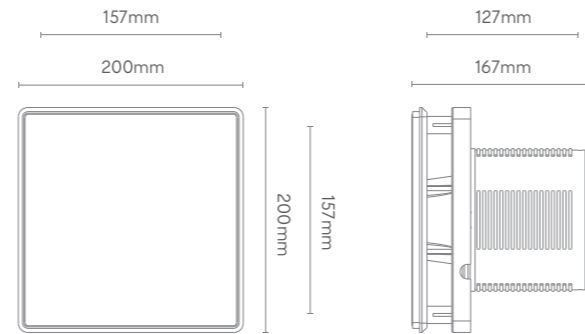

Rich Black



Rich Black

PRODUCT HIGHLIGHTS

- Fresh ABS Plastic Material · Better Air Suction · Black Glass with LED Light
- Perametrical Air Extraction · Quite & Longer Durability
- Thermo Cut-off Protection · Smooth & Silent Operation



FROST PRIME

ITEM CODE	SWEEP	WATTAGE	SPEED	AIR DELIVERY
AFP 700704	100 mm	15 W	2200 RPM	75 CMH
AFP 700706	150 mm	25 W	1900 RPM	236 CMH

FROST

ITEM CODE	SWEEP	WATTAGE	SPEED	AIR DELIVERY
AFP 700806	150 mm	25 W	1900 RPM	236 CMH



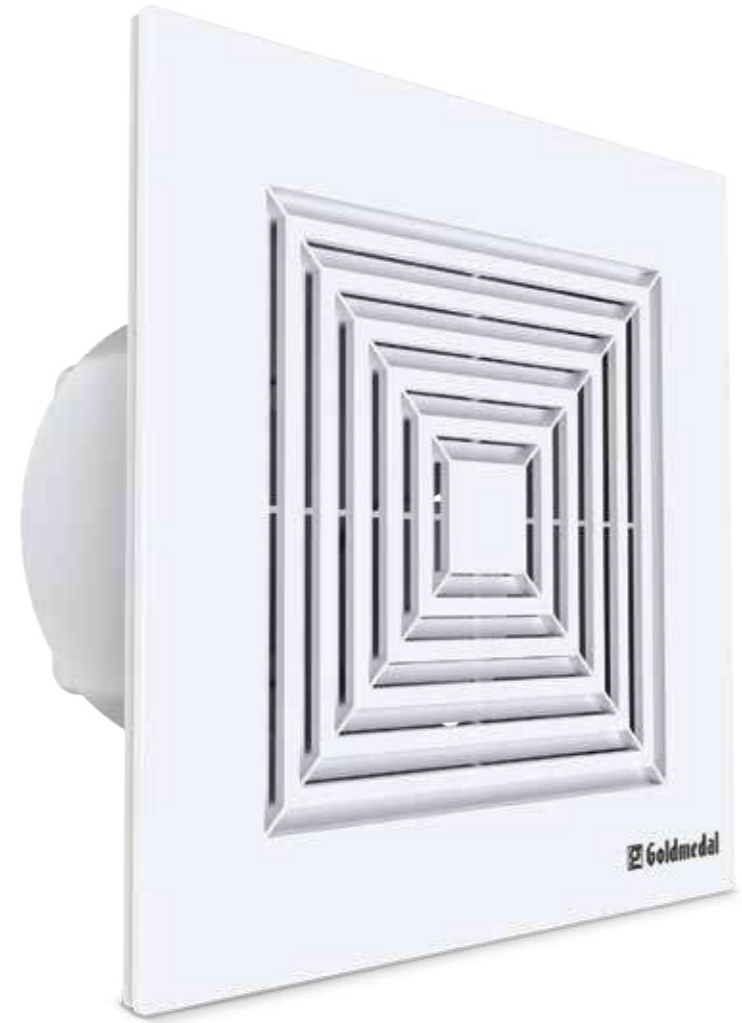

AIR VENT CM
Axial Exhaust Fan

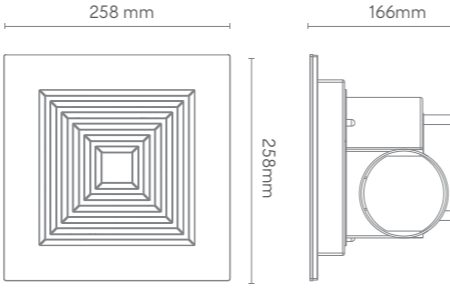

Ensure fresh air circulation in your homes with the Air Vent CM (ceiling mounting) exhaust fans. The curved blades of the exhaust fans produce efficient air movement to extract stale air and replace it with fresh air. Easy to maintain, the Air Vent CM fans are designed innovatively for contemporary homes.



White

PRODUCT HIGHLIGHTS

- Super Efficient Motor
- Detachable Front Grill
- Unique & Sleek Design
- Easy to Install
- Low Power Consumption
- Smooth & Silent Operation
- Roof / Ceiling Mounting



ITEM CODE	SWEEP	WATTAGE	SPEED	AIR DELIVERY
EFP 800108	200 mm	65 W	2100 RPM	750 CMH





NOVA | NOVA PRO

Axial Exhaust Fan



The Nova axial fans are designed brilliantly for effortless suction of hot and humid air. The strong turbo motor and lightweight blades of the Nova and Nova Pro fan ensure speedy rotation which leads to fresh air delivery. The Nova Pro sports a backlit LED in addition to the wavy bird screen that goes well with modern interiors.

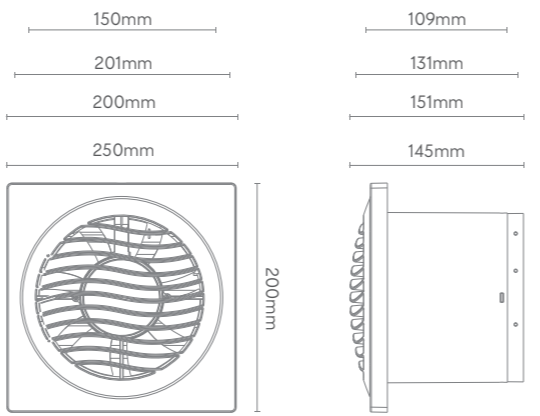

White



White

PRODUCT HIGHLIGHTS

- Super Efficient Motor • Detachable Front Grill • Unique & Sleek Design • LED Light • Easy To Install
- Better Air Suction • Low Power Consumption • Smooth & Silent Operation



NOVA

ITEM CODE	SWEEP	WATTAGE	SPEED	AIR DELIVERY
AFS 751104	100 mm	14 W	2200 RPM	90 CMH
AFS 751106	150 mm	21 W	1800 RPM	250 CMH
AFS 751108	200 mm	24 W	2000 RPM	350 CMH

NOVA PRO WITH LED LIGHT

ITEM CODE	SWEEP	WATTAGE	SPEED	AIR DELIVERY
AFP 701006	150 mm	24 W	2000 RPM	350 CMH

*Nova 150 mm also available in BLDC motor





AERO

Axial Exhaust Fan

The Aero axial fan is as sturdy as it is stylish. It is manufactured using high quality ABS plastic and is equipped with an LED indicator. The Aero with a circular design and super-efficient motor allows you to keep interiors fresh by venting out unpleasant smoke and odour. The Aero axial fan is available in White shade.



PRODUCT HIGHLIGHTS

- Super Efficient Motor • Detachable Front Panel • Unique & Sleek Design
- Easy To Install • Low Power Consumption • Center LED Indicator
- Smooth & Silent Operation

ITEM CODE	SWEEP	WATTAGE	SPEED	AIR DELIVERY
AFS 750706	150 mm	25 W	2250 RPM	240 CMH



White



ARIA

Axial Exhaust Fan

The pyramid-shaped Aria axial fan is a perfect example of powerful performance combined with a trendy appearance. This high speed axial fan with strong suction power provides vibration-free ventilation ensuring that the room is free of any unpleasant odour. The Aria is available in two evergreen shades that suit every home and office.



PRODUCT HIGHLIGHTS

- Super Efficient Motor • Detachable Front Panel • Unique & Sleek Design
- Easy To Install • Energy Efficient • Center LED Indicator
- Smooth & Silent Operation

ITEM CODE	SWEEP	WATTAGE	SPEED	AIR DELIVERY
AFS 750906	150 mm	25 W	2250 RPM	240 CMH



White



Black





TRIGO
Axial Exhaust Fan



NOISELESS OPERATION



ENERGY EFFICIENT

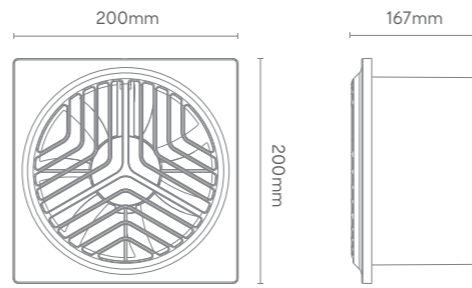

The Trigo axial fan combines sleek, stylish design with practical functionality, featuring an ABS plastic body and blades that ensure high air delivery. Equipped with a super-efficient motor, it operates smoothly, offering outstanding performance. Available in two attractive shades, this fan not only enhances the aesthetic of any room but also brilliantly eliminates hot and humid air, making it an ideal choice for maintaining a comfortable and fresh environment.



White



Black

PRODUCT HIGHLIGHTS

- Super Efficient Motor
- Detachable Front Grill
- Unique & Sleek Design
- Easy To Install
- Low Power Consumption
- Smooth & Silent Operation

POWERFUL MOTOR
 ENERGY EFFICIENT
 EASY CLEANING & MAINTENANCE
 NOISELESS OPERATION
 POWERFUL EXHAUST
 EASY INSTALLATION

ITEM CODE	SWEEP	WATTAGE	SPEED	AIR DELIVERY
AFS 750106	150 mm	22W	2250 RPM	240 CMH





VENTO
Axial Exhaust Fan



The Vento axial fan, powered by a robust motor, ventilates the room with ease and speed. Designed using long lasting and featherlight ABS plastic, the Vento can be easily installed into your homes and offices. Adorning a classic front shield look, the Vento can effortlessly blend into the surrounding decor.

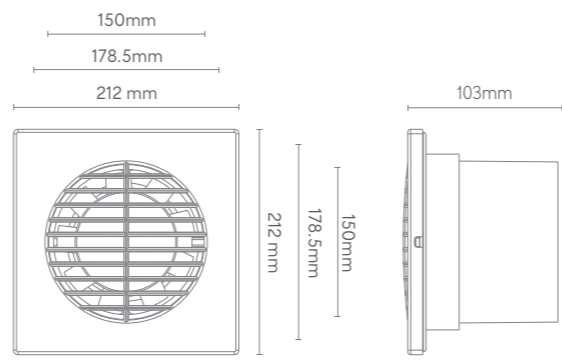

Ivory



Black

PRODUCT HIGHLIGHTS

- Super Efficient Motor
- Detachable Front Grill
- Unique & Sleek Design
- Easy To Install
- Low Power Consumption
- Smooth & Silent Operation



ITEM CODE	SWEEP	WATTAGE	SPEED	AIR DELIVERY
AFS 751504	100 mm	18 W	2500 RPM	90 CMH
AFS 751506	150 mm	22 W	1800 RPM	250 CMH
AFS 751508	200 mm	25 W	2000 RPM	350 CMH





Ivory

VENTFLO
Axial Exhaust Fan



Crafted from durable yet lightweight ABS plastic, the Ventflo fan is a breeze to set up in both home and office spaces. It is driven by a strong motor that efficiently refreshes any room quickly. It features an innovative fin mechanism that closes when not in use and, upon operation, the fins open gracefully. With its timeless front shield design, the Ventflo seamlessly integrates with any interior design scheme.

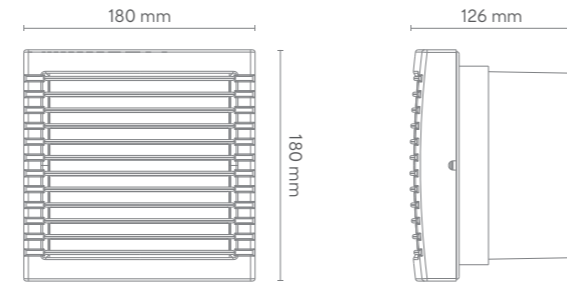

PRODUCT HIGHLIGHTS

- Super Efficient Motor
- Detachable Front Grill
- Glass Mountable
- Unique & Sleek Design
- Easy To Install
- Rust-proof Plastic Body
- Ideal For Bathrooms, Kitchens & Closed Rooms

ENERGY EFFICIENT
 POWERFUL MOTOR
 NOISELESS OPERATION
 POWERFUL EXHAUST
 EASY CLEANING & MAINTENANCE
 EASY INSTALLATION

ITEM CODE	SWEEP	WATTAGE	SPEED	AIR DELIVERY
AFP 751706	150 mm	22W	1800 RPM	250 CMH



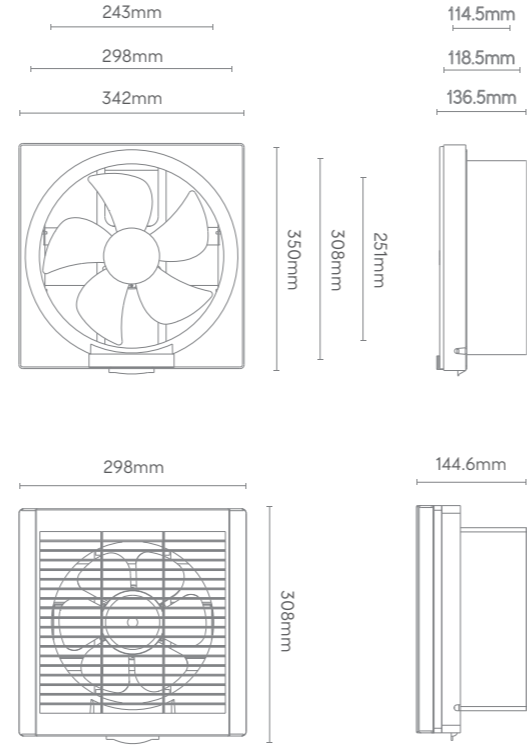
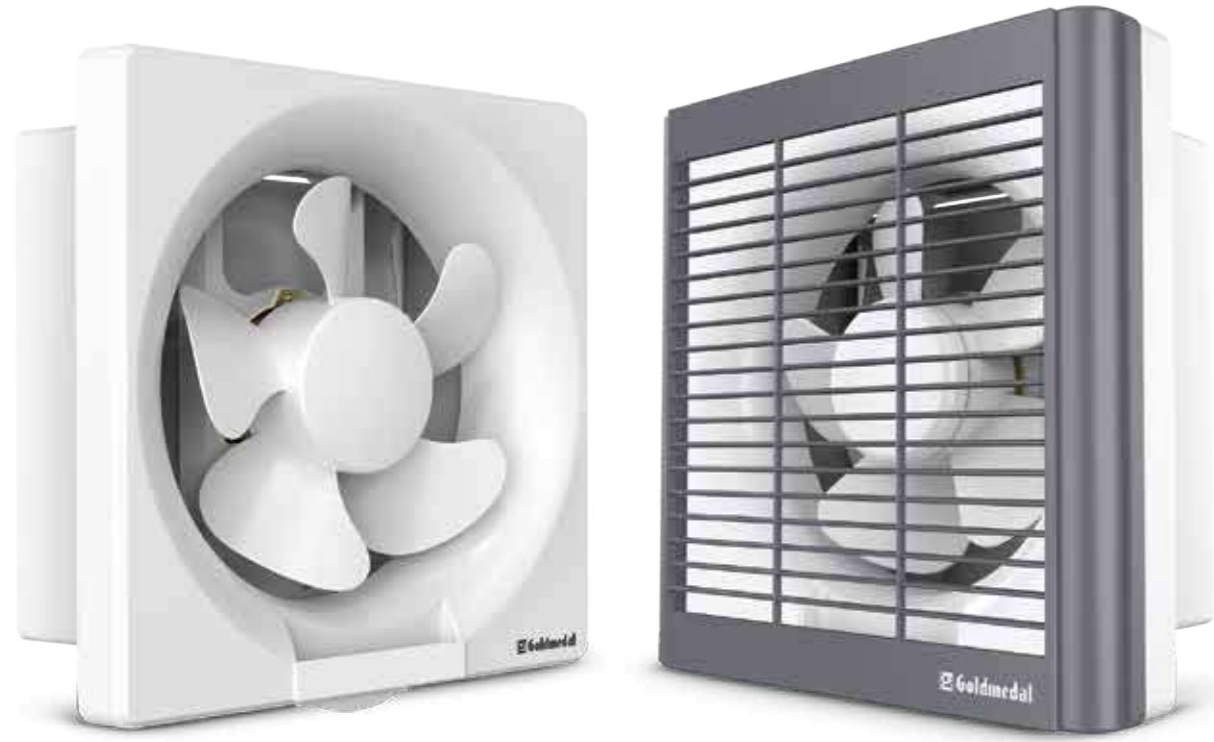

AIR-MAXX | AIR-MAXX HS AIR-MAXX PLUS

Exhaust Fan

Introducing the Air Maxx Series: Air-Maxx, Air Maxx HS, and Air Maxx Plus. Each model is uniquely designed to enhance air quality in a variety of environments. These exhaust fans offer a dynamic solution for hot and humid conditions. The Air Maxx HS features a highly efficient motor and a dust protection shutter, ensuring durability and sustained performance. Crafted from robust ABS plastic, the Air Maxx series excels in longevity and resilience, effortlessly performing in humid atmospheres.

PRODUCT HIGHLIGHTS

- Super Efficient Motor
- Dust Protection Shutter
- Sleek & Trendy Design
- Smooth & Silent Operation
- Detachable Front Grill
- Easy To Install



White



Black



White-Grey

AIR-MAXX

ITEM CODE	SWEEP	WATTAGE	SPEED	AIR DELIVERY
EFS 850306	150 mm	35W	1350 RPM	280 CMH
EFS 850308	200 mm	38W	1300 RPM	550 CMH
EFS 850310	250 mm	40W	1250 RPM	750 CMH

AIR-MAXX HS

ITEM CODE	SWEEP	WATTAGE	SPEED	AIR DELIVERY
EFS 850506	150 mm	40W	2500 RPM	500 CMH
EFS 850508	200 mm	65W	2100 RPM	750 CMH

AIR-MAXX PLUS

ITEM CODE	SWEEP	WATTAGE	SPEED	AIR DELIVERY
EFS 850408	200 mm	38W	1300 RPM	550 CMH





HAVOC | HAVOC PLUS

Ex Vent Exhaust Fan



Unleash the power of clean air with Havoc and Havoc Plus a masterclass in efficient air suction. Engineered with a robust motor and precision-crafted metal blades, this fans effortlessly eliminate dirt and fumes, ensuring that your home remains pristine. The sturdy bird guard blocks unwanted particles, while the rubber gasket guarantees vibration-free operation. Its durable, powder-coated finish and strong body withstand the test of time and the elements, while its stylish blue frame adds a touch of elegance.

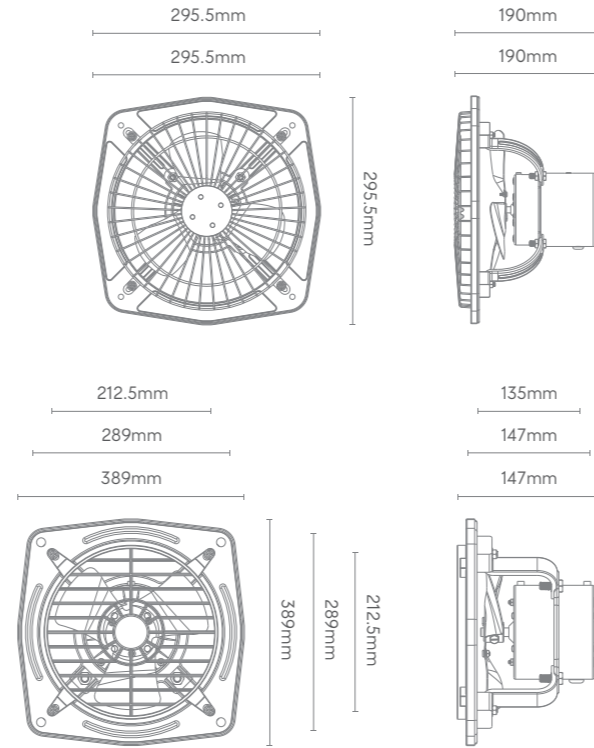

Grey

Grey

PRODUCT HIGHLIGHTS

- Powerful Motor · Powder Coated Finish · Sturdy Bird Guard
- Specially Designed Metal Blade · Rubber Gasket



HAVOC

ITEM CODE	SWEEP	WATTAGE	SPEED	AIR DELIVERY
EFS 850906	150 mm	40W	2350 RPM	350 CMH
EFS 850909	225 mm	35W	1350 RPM	750 CMH
EFS 850912	300 mm	45W	1350 RPM	1150 CMH

HAVOC PLUS

ITEM CODE	SWEEP	WATTAGE	SPEED	AIR DELIVERY
EFS 851009	225 mm	70W	2400 RPM	1050 CMH
EFS 851012	300 mm	75W	2250 RPM	1600 CMH





RAPIDO
Ex Vent Exhaust Fan

Count on the Rapido to rapidly clear the room of fumes and humid air. This heavy duty exhaust fan boasts a high speed, powerful motor that has high air thrust to clear the air. Its specially designed metal blade with powder coated finish prevents corrosion and thus extends its lifespan. With a classic design, the Rapido also features a sturdy bird guard that prevents the entry of birds into your premises.

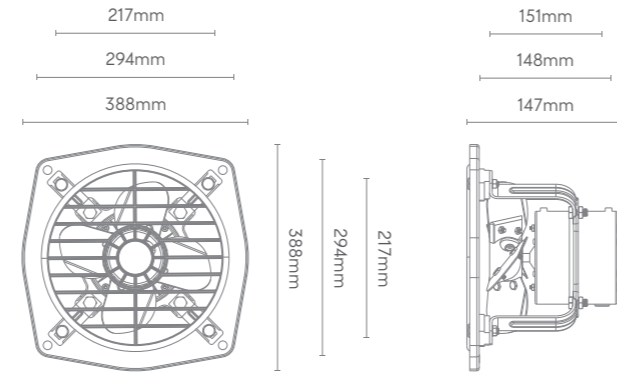

Grey

PRODUCT HIGHLIGHTS

- High Speed Powerful Motor · High Air Thrust · Sturdy Bird Guard
- Specially Designed Metal Blade · Powder Coated Finish



ITEM CODE	SWEEP	WATTAGE	SPEED	AIR DELIVERY
EFS 851306	150 mm	50 W	2050 RPM	600 CMH
EFS 851309	225 mm	46 W	1380 RPM	550 CMH
EFS 851312	300 mm	52 W	1380 RPM	1200 CMH



CEILING FANS



LIFESTYLE FANS



PERSONAL FANS



TABLE FANS



WALL FANS

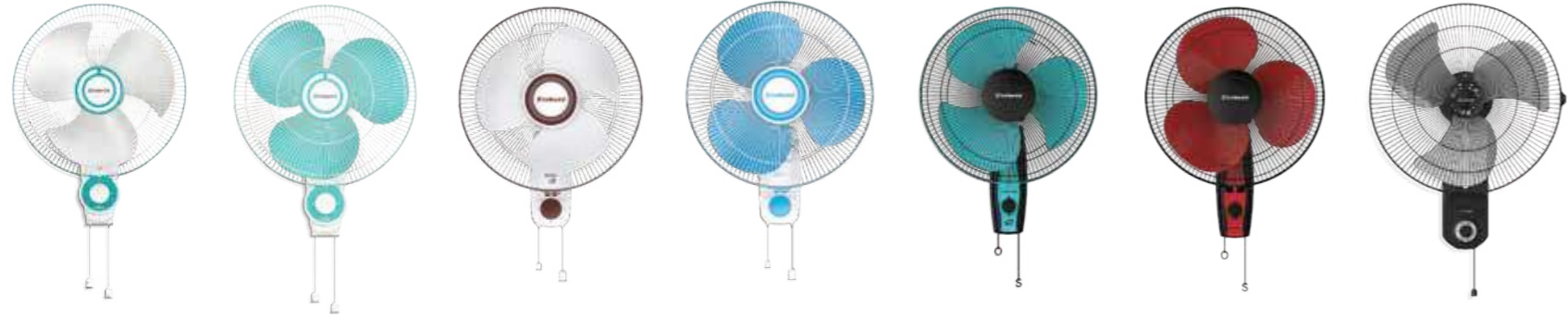

STORM (HS) STORM NORA ERICA DYN0 PRO DYN0 G-EXPRESS

PEDESTAL FANS



STORM (HS) STORM NORA ERICA DYN0 PRO DYN0 FALCON / FALCON PRO G-EXPRESS TURBO MAXX / TURBO STAR

AXIAL FANS



FROST FROST PRIME AIR VENT CM NOVA PRO NOVA AERO ARIA TRIGO



VENTO VENTFLO

VENTILATION FANS



AIR-MAXX HS | AIR-MAXX AIR-MAXX PLUS HAVOC HAVOC PLUS RAPIDO

CEILING FANS

CATEGORY	MODEL CODE	MODEL NAME	SWEEP (MM)	POWER (WATT)	SPEED (RPM)	AIR DELIVERY (CMM)	WARRANTY (YEARS)	PKG
Super Decorative	SCFZ101948	FABIA	1200	53	350	220	2	2
	SCFZ101050	HUSH FLO BLDC	1250	36	300	230	2+1*	2
	CFZ100750	HUSH-AIR	1250	53	300	230	2	2
	SCFP301948	OPUS PRIME BLDC	1200	30	350	225	3+2*	2
	SCFZ101448	DAISY	1200	40	330	210	2	1
Decorative	SCFZ100148	PHANTOM	1200	40	330	210	2	1
	SCFZ100948	GLADIATOR	1200	52	350	220	2	2
	SCFZ101124	THOR	600	65	850	105	2	4
	SCFP300348	FLORA	1200	50	350	220	2	2
	SCFP301548	HERO PRIME	1200	53	380	230	3	2
	SCFP300536	INSIGNIA	900	41	400	130	2	2
	SCFP300548	INSIGNIA	1200	53	380	220	2	2
	SCFP300556	INSIGNIA	1400	59	310	245	2	2
	SCFP301136	HOOPLA	900	45	450	140	2	2
	SCFP301148	HOOPLA	1200	53	380	225	2	2
	SCFP300948	SENORA	1200	52	380	210	2	4
	SCFP301748	EVA PRIME	1200	53	350	220	2	4
	SCFP301324	ENZO	600	65	850	105	2	4
	SCFP301336	ENZO	900	45	450	140	2	4
	SCFP301348	ENZO	1200	50	380	220	2	4
Classic Decorative	SCFS501448	AIR CREST	1200	50	350	210	3	4
	SCFS500848	VECTOR	1200	52	400	215	2	4
Standard	SCFS500348	GATI DECO 400	1200	50	400	210	2	4
	SCFS500948	GEO FOX BLDC	1200	35	350	220	2	4
	SCFS500748	MARUT BLDC	1200	30	350	215	2+1*	4
	SCFS502148	EN SAVER BLDC	1200	30	350	215	2	4
	SCFS501348	LEGACY 390	1200	52	400	225	3+2*	4
	SCFS501248	AIRAVAT	1200	53	350	220	3	4
	SCFS502048	VELLFIRE	1200	53	350	220	5	4
SCFS501148	STORM	1200	53	380	220	2	4	

Note: *extended warranty only on registration of product.

CEILING FANS

CATEGORY	MODEL CODE	MODEL NAME	SWEEP (MM)	POWER (WATT)	SPEED (RPM)	AIR DELIVERY (CMM)	WARRANTY (YEARS)	PKG
Economy	SCFE700148	VEGAH 400	1200	50	400	210	2	4
	SCFS501824	GATI NEO 600	600	70	850	110	2	4
	SCFS501836	GATI NEO 900	900	41	450	130	2	4
	SCFS501848	GATI 400 NEO	1200	50	400	210	2	4
	SCFS501856	GATI NEO 1400	1400	59	310	245	2	4
	SCFS501624	VOLT 600	600	65	850	100	2	4
	SCFS501636	VOLT 400 900	900	40	450	130	2	4
	SCFS501648	VOLT 400 1200	1200	52	400	210	2	4
	SCFE700448	AIR-GT	1200	52	400	210	2	4
	SCFE700648	G-BLISS	1200	52	350	220	2	4
	SCFS501936	VOLT 650	900	52	630	165	2	4

LIFESTYLE & PORTABLE FANS

	LFP801000	OXYRICH	-	48	-	-	2	1
	PFP300216	VISTA 360	400	53	1158	65	2	1
	PFP300316	SPEEDO-X	400	130	2350	100	2	1
	PFP300716	GRACE	400	56	1230	75	2	1
	PFP300616	FUSION	400	53	1245	75	2	1
	LFP800118	TRICOOL	450	80	1350	105	2	1
	PFP300118	AIR FIESTA	450	90	1350	100	2	1
	WFP200416	FUSION DG	400	68	1350	75	2	1
	WFP200316	FUSION	400	53	1245	75	2	1
	WFP200716	ADORA	400	55	1200	90	2	1

PERSONAL FANS

	PCS650409	I-FRESH	230	28	2200	25	2	4
	PCS650909	TRISTAR	225	45	2200	25	2	4
	PCS650212	ASTOR	300	75	2200	60	2	4
	PCS650509	AIR ON	230	50	2500	30	2	4

CEILING FANS

CATEGORY	MODEL CODE	MODEL NAME	SWEEP (MM)	POWER (WATT)	SPEED (RPM)	AIR DELIVERY (CMM)	WARRANTY (YEARS)	PKG
Table Fan	TFS150116	STORM HS	400	110	2200	100	2	2
	TFS150216	STORM	400	55	1350	75	2	2
	TFS153516	NORA	400	110	2200	100	2	2
	TFS153616	ERICA	400	55	1350	75	2	2
	TFS400416	DYNO PRO	400	110	2200	100	2	2
	TFS400716	DYNO	400	55	1350	75	2	2
Wall Fan	WFS253616	STORM HS	400	110	2200	100	2	2
	WFS253716	STORM	400	55	1350	75	2	2
	WFS253512	NORA	300	65	2200	75	2	2
	WFS253516	NORA	400	110	2200	100	2	2
	WFS250516	ERICA	400	55	1350	75	2	2
	WFS250416	DYNO PRO	400	100	2200	100	2	2
	WFS250716	DYNO	400	55	1350	75	2	2
	WFS200618	G-EXPRESS	450	90	1350	100	2	2
Pedestal Fan	PFS403616	STORM HS	400	110	2200	100	2	2
	PFS403716	STORM	400	55	1350	75	2	2
	PFS403516	NORA	400	110	2200	100	2	2
	PFS400516	ERICA	400	55	1350	75	2	2
	PFS400416	DYNO PRO	400	110	2100	90	2	2
	PFS400716	DYNO	400	55	1350	75	2	2
	FFS550316	FALCON	400	105	2100	125	2	2
	PFS400816	FALCON PRO	400	105	2100	125	2	2
	FSS550618	G-EXPRESS	450	90	1350	100	2	2
	FSS550220	TURBO MAXX	500	135	1350	120	2	1
PFS400116	TURBO STAR	500	135	1350	120	2	1	

AXIAL & VENTILATION FANS

CATEGORY	MODEL CODE	MODEL NAME	SWEEP (MM)	POWER (WATT)	SPEED (RPM)	AIR DELIVERY (CMH)	WARRANTY (YEARS)	PKG
Axial Fan	AFP700806	FROST	150	25	1900	236	2	12
	AFP700704	FROST PRIME	100	15	2200	75	2	16
	AFP700706	FROST PRIME	150	25	1900	236	2	12
	EFP800108	AIR VENT CM	200	65	2100	750	2	8
	AFS751104	NOVA	100	14	2200	90	2	12
	AFS751106	NOVA	150	21	1800	250	2	12
	AFS751108	NOVA	200	24	2000	350	2	8
	AFP701006	NOVA PRO	150	24	2000	350	2	12
	AFS750706	AERO	150	25	2250	240	2	8
	AFS750906	ARIA	150	25	2250	240	2	8
	AFS750106	TRIGO	150	22	2250	240	2	12
	AFS751504	VENTO	100	18	2500	90	2	12
	AFS751506	VENTO	150	22	1800	250	2	8
	AFS751508	VENTO	200	25	2000	350	2	8
	AFS751706	VENT FLO	150	22	1800	250	2	8
	Vent Fan	EFS850306	AIR MAXX	150	35	1350	280	2
EFS850308		AIR MAXX	200	38	1300	550	2	4
EFS850310		AIR MAXX	250	40	1250	750	2	4
EFS850506		AIR MAXX HS	150	40	2500	500	2	6
EFS850508		AIR MAXX HS	200	65	2100	750	2	4
EFS850408		AIR MAXX PLUS	200	38	1300	550	2	4
EFS850906		HAVOC (HIGH SPEED)	150	40	2350	350	2	6
EFS850909		HAVOC	225	35	1350	750	2	4
EFS850912		HAVOC	300	45	1350	1150	2	4
EFS851009		HAVOC PLUS	225	70	2400	1050	2	4
EFS851012		HAVOC PLUS	300	75	2250	1600	2	4
EFS851306		RAPIDO	150	50	2050	600	2	4
EFS851309	RAPIDO	225	46	1380	550	2	4	
EFS851312	RAPIDO	300	52	1380	1200	2	4	

SHOWROOMS

WEST

MUMBAI
E-1, Laxmi Industrial Estate,
New Link Road,
Andheri West, Mumbai - 400053
Tel: +91-22-40031075
Email: info@goldmedalindia.com

AHMEDABAD
106, Arista, 1st Floor, Opp Stellar,
Sindhu Bhavan Road, Ahmedabad-380058
+91-8104965389
info@goldmedalindia.com

EAST

KOLKATA
Merlin Homeland Mall, Shop No. 123,
1st Floor, 18B, Ashutosh Mukherjee Road,
Bhawanipore, Kolkata-700020.
Tel:+91- 8336956017
Email: kolkata@goldmedalindia.com

SILIGURI
International Market, 2nd Floor,
Shop No. 3 & 4,
Sevoke Road, Near Panitanki More,
Beside Sky Star Building, Siliguri - 734001,
West Bengal. Tel: +91-8336084284
Email: ritesh.g@goldmedalindia.co.in

NORTH

JODHPUR
Plot No. E-99A, M. I. A.
Basni 2nd Phase, Jodhpur,
Rajasthan - 342005.
+91-9772210543
rajasthan@goldmedalindia.com

NOIDA
H-204, Sec-63
Noida, Uttar Pradesh - 201307
Tel: +91-120-4135901
Email: noida@goldmedalindia.com

JAIPUR
Goldmedal Electricals Private Limited
55, New Aatish Market, Mansarovar,
Jaipur - Rajasthan.
Tel: +91-291-3261955
Email: rajasthan@goldmedalindia.com

JALORE
Head Post Office Road,
Jalore - 343001, Rajasthan, India.
Tel: +91-2973222568
Email: rajasthan@goldmedalindia.com

SOUTH

HUBBALLI
Umachagi Complex, Koppikar Road, Hubballi,
Karnataka-580020
Tel: +91-0836-4258466
Email: bangalore@goldmedalindia.com

HYDERABAD
S-1, Ground Floor, Kalphakunja
Apartment 5-2-84/87, Jambagh,
Hyderabad-500095, Telangana
Tel: +91-40-24610722 / 9849172122
Email: hyderabad@goldmedalindia.com

VIJAYAWADA
2nd Floor, PVP Mall, Mahatma Gandhi Rd,
Labbipet, Vijayawada-520010, Andhra Pradesh
Tel: +91-9885676400
Email: vijayawada@goldmedalindia.com

VIJAYAWADA
D. No. 11-33-15, Tatakulavari Street,
Vijayawada-520 001, Andhra Pradesh
Tel: +91-866-6542000 / 8977574737
Email: vijayawada@goldmedalindia.com

KADAPA
21/96, Reddy Complex, Near 7 Road Circle,
Opp. Reddy Express, Kadapa- 516001,
Andhra Pradesh. Tel: +91-9885676400
Email: vijayawada@goldmedalindia.com

CALICUT
Shaherzad Shopping Complex, CH Flyover
Junction, Cherrooty Road, Calicut - 673001,
Kerala. Tel: +91-9048743111
Email: calicut@goldmedalindia.com

COCHIN
3rd Floor, G K Arcade, Palarivattom
Bye Pass Junction,
Ernakulam - 682028, Kerala.
Tel: +91-9324936290
Email: calicut@goldmedalindia.com

COIMBATORE
D. No. 897, Avinashi Road,
Below Flyover,
Coimbatore-641018
+91-9324514945
chennai@goldmedalindia.com

BRANCHES

WEST

MUMBAI
119, Maskati Mahal, 3rd Floor, Room No.1- B,
Loharchawl, Marine Line, Mumbai - 400002,
Maharashtra, India. Tel: +91-022-69333558/511
Mob. : 9320687515
Email: info@goldmedalindia.com

PALGHAR
Bldg. No.5, Shah Industrial Estate, Opp. Masjid,
Mourya Naka, Sativali, Vasai (E), Palghar-401208,
Maharashtra. Tel: +91-22-42023026
Email: mumbai@goldmedalindia.com

PUNE
741/1, Shop No.1 & 2, Gr. Floor, Kushal Sagar
Complex, Ganesh Rd, Budhwar Peth, Pune-411002,
Maharashtra, India. Tel: +91-9822098620
Email: pune@goldmedalindia.com

AHMEDABAD
Block No. 43, Behind Savex Technologies
Warehouse, Sanathal Bakrol Ring Road,
Village Badrabad, Ahmedabad, Gujarat- 382210
Tel: +91-9372200393
Email: ahmedabad@goldmedalindia.com

BHOPAL
Way No. 11-12, Multi Industries Warehouse,
Plot No. 13C, Industrial Area Govindpura,
Bhopal, Madhya Pradesh - 462023
Tel: +91-9589080144
Email: bhopal@goldmedalindia.com

RAIPUR
1st Floor, Plot No.15, Kedia Business Park,
Tatibandh, Raipur, Raipur - 492099,
Chhattisgarh, India. Tel: +91-7714910078
Email: raipur@goldmedalindia.com

EAST

KOLKATA
1/1B/4, Ram Krishna Naskar Lane Beliaghata,
Kolkata - 700010, West Bengal.
Tel: +91-8336907040
Email: kolkata@goldmedalindia.com

PATNA
Plot No.846, Mohalla East Ashu Chak,
P.o. Purvilakshmi Nagar, Krishna Niketan
School Road, Agamkuan, Patna-800030,
Bihar, India. Tel: +91-9798606400
Email: patna@goldmedalindia.com

RANCHI
R S Plot No. 2072, Near Dalaldali Chowk,
Simaliya, P. S, Ratu Ranchi-834005,
Jharkhand, India.Mobile- 9431170402
Email: ranchi@goldmedalindia.com

GUWAHATI
NH-37, Nr. Tirupati Parking, Opp. Audi Showroom,
Guwahati-781029, Assam, India. Tel: +91- 9718077070.
Email: guwahati@goldmedalindia.com

CUTTACK
Plot No.1047 & 1048, Opp. Axis Bank, Jagatpur,
Cuttack- 754021, Odisha (Orissa), India.
Tel: +91- 9437452303
Email: cuttack@goldmedalindia.com

NORTH

JODHPUR
Plot no. E-99A, M. I. A. Basni 2nd Phase,
Jodhpur, Rajasthan-342005. Tel: +91-9772210543
Email: rajasthan@goldmedalindia.com

LUCKNOW
C1-5, Phase-2, Transport Nagar, Lucknow-226012,
Uttar Pradesh, India.Tel: +91-8780887400
Email: lucknow@goldmedalindia.com

NOIDA
H-204, Sec-63, Noida, Uttar Pradesh-201307
Tel: +91-120-4135901
Email: noida@goldmedalindia.com

DEHRADUN
A-39, Transport Nagar, Sewla Khurd, Dehradun-248001,
Uttarakhand, India. Tel: +91-135 - 2649522
Email: dehradun@goldmedalindia.com



MOHALI
855/C, Janta Industrial Estate, Sector - 82,
Mohali, Mohali-160055, Punjab, India.
Customer Care : 9711 09 09 09
Email: mohali@goldmedalindia.com

SOUTH

BENGALURU
Level 2/3/4, Regal Arcade No. 1-2, 5th Cross,
Mysore Road, Bengaluru, Karnataka - 560026
Tel: +91-80-41687799/41759977
Email: bangalore@goldmedalindia.com

VIJAYAWADA
20-127/2, By Pass Road, Gollapudi, Krishna
District, Vijayawada - 521225, Andhra Pradesh
Tel: +91-866-6542333/6542888
Email: vijayawada@goldmedalindia.com

HYDERABAD
Central Warehouse Corporation A2, P B No 34,
Behind Gandhi Bhavan, Nampally, Hyderabad
-500001, Telangana. Tel: +91-40-29706099
Email: hydteam@goldmedalindia.com

CHENNAI
92/6, Nattu Pillaiar Koil Street Sowcarpet,
Chennai - 600001, Tamil Nadu, India.
Tel: +91-44-49521008
Email: chennai@goldmedalindia.com

CALICUT
Door No.1/60, Baby Marine Export Compound,
Temple Road, West Hill Calicut, Kozhikode (Calicut),
Kozhikode-673005, Kerala, India.
Customer Care : 9711 09 09 09
Email: calicut@goldmedalindia.com

NOTES

NOTES

Regd. office:

Goldmedal Electricals Pvt. Ltd.

A/303, Kemp Plaza, Off Link Road,
MindSpace, Chincholi Bunder, Malad (W),
Mumbai-400064, Maharashtra, India

Web: www.goldmedalindia.com

Email: info@goldmedalindia.com

Customer care no.: 91-9711 09 09 09

Goldmedal, Curve, Nixon, Air, Ringo,
Gifa & Cloud9 are registered trademarks
of Goldmedal Electricals Pvt. Ltd.

Copyright protected by Goldmedal. No part of this
pricelist & catalogue may be printed or duplicated
without consent of Goldmedal Electricals Pvt.

Ltd. Patent, Trademark & Designs protected.

Infringement is liable for prosecution. Imitation
of graphics is a punishable offence.

Brand identity, concept & design of
Goldmedal Electricals Pvt. Ltd.



SCAN this QR-code from your
smart phone to visit our website



Chat with us on whatsapp for any query or complaint +91 9711 09 09 09.

Term & Conditions

Warranty applicable on products are as per
Goldmedal's warranty policy.

Continuous design and product development is a routine
practice at Goldmedal, so data in this catalogue
provided may change without prior information or
notice. Customers are advised to check current data
before purchasing any product.

